

# SERVICE MANUAL FOR DB2-B773 DB2-B774 DB2-B7740

SINGLE NEEDLE ADJUSTABLE TOP AND  
BOTTOM FEED LOCK STITCH MACHINE

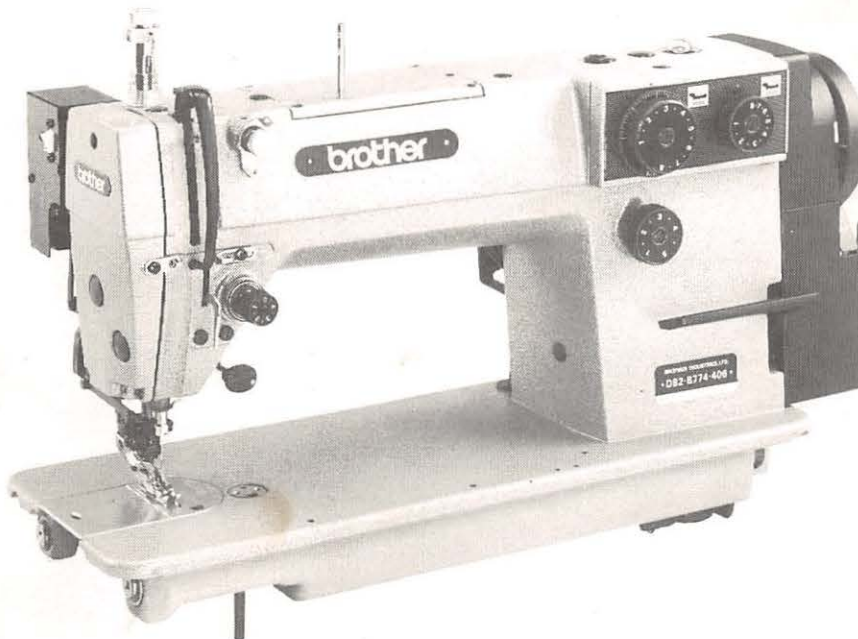

# CONTENTS

<b>NAMES OF MAIN PARTS</b>	1
<b>SPECIFICATIONS</b>	3
<b>MECHANICAL DESCRIPTIONS</b>	5
① Upper shaft and needle bar mechanism	5
② Lower shaft and rotary hook mechanism	5
③ Upper feed mechanism	6
④ Feed mechanism	7
⑤ Feed adjusting mechanism and quick reverse mechanism	8
⑥ Upper feed mechanism and shirring mechanism (subclass -006)	9
⑦ Thread trimmer	10
⑧ Tension release	13
⑨ Thread wiper (subclasses -400, -900)	13
⑩ Automatic presser bar lifter mechanism (subclass -900)	14
⑪ Lubrication mechanism	15
<b>DISASSEMBLY</b>	17
① Machine covers	17
② Presser foot mechanism	18
③ Upper feed mechanism	18
④ Rotary hook mechanism	19
⑤ Thread trimmer	19
⑥ Feed mechanism	20
⑦ Needle bar mechanism	21
<b>ASSEMBLY</b>	22
① Needle bar mechanism	22
② Feed mechanism	23
③ Thread trimmer	25
④ Rotary hook mechanism	27
⑤ Presser foot mechanism	28
⑥ Upper feed mechanism	29
⑦ Machine covers	30
<b>ADJUSTMENT</b>	31
① Adjusting the timing between needle and rotary hook	31
② Adjusting the timing between needle and feed	32
③ Adjusting the forward and backward stitch lengths	33
④ Zeroing feed regulator and adjusting reverse lever	34
⑤ Adjusting the timing of upper feed horizontal movement	35
⑥ Adjusting the timing of the upper feed vertical movement	36
⑦ Adjusting presser foot	37

8	Adjusting thread trimmer .....	38
9	Adjusting tension release .....	39
10	Adjusting thread tension .....	40
11	Adjusting synchronizer (DB2-B774) .....	41
12	Adjusting thread wiper .....	42
13	Adjusting potentio-meter (B7740) .....	43
14	Checking feed mechanism weight (B7740) .....	44
15	Adjusting sensor position .....	45
16	Adjusting the indication of the distance between needle hole and sensor (B7740) .....	46
<b>REPLACEMENTS</b> .....		<b>47</b>
1	Replacing Solenoids .....	47
2	Replacing tension release wire .....	50
3	Replacing bobbin tension spring .....	50
4	Replacing photo-cell and reflector (B7740) .....	51
5	Replacing Synchronizers .....	53
<b>OPTIONAL EQUIPMENT</b> .....		<b>54</b>
1	Thread wiper .....	54
2	Presser foot lifting solenoid set .....	55
<b>TROUBLESHOOTING GUIDE</b> .....		<b>59</b>

# NAMES OF MAIN PARTS

[DB2-B773-003]



- ① Needle bar
- ② Presser regulating screw
- ③ Thread retainer
- ④ Tension nut

[DB2-B773-006]

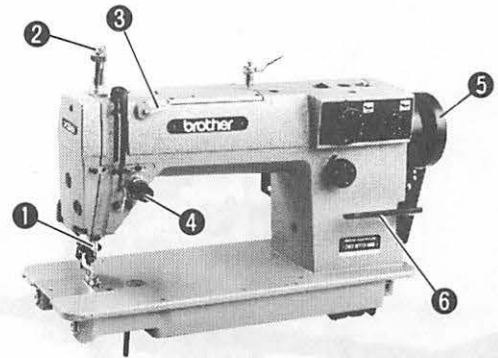

- ⑤ Machine pulley
- ⑥ Reverse lever

[DB2-B774]

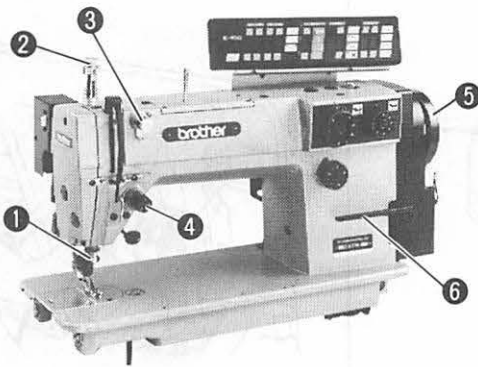

- ① Needle bar
- ② Presser regulating screw
- ③ Pre-tension
- ④ Tension nut

[DB2-B7740]

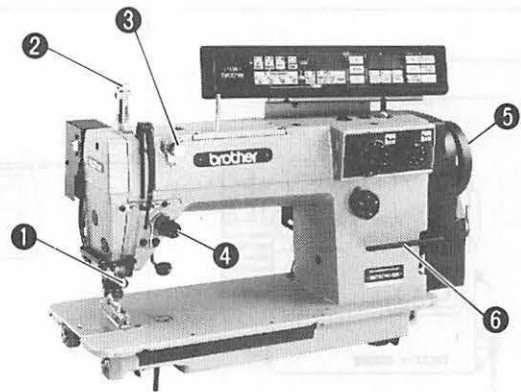

- ⑤ Machine pulley
- ⑥ Reverse lever

Control panel (B7740)

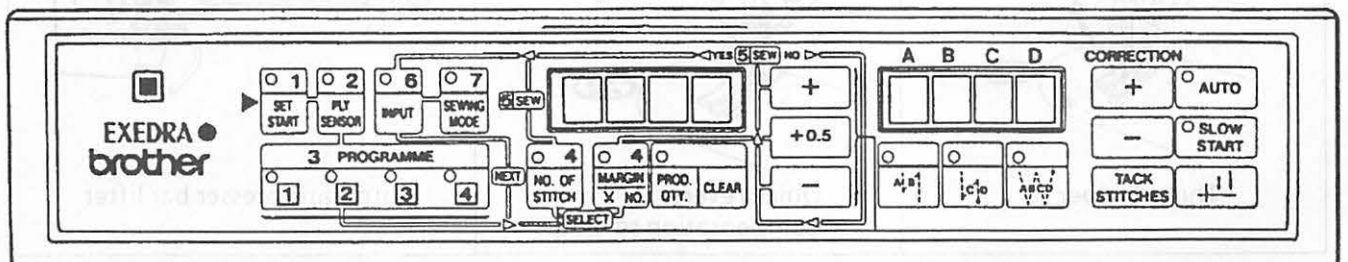

Base

[DB2-B774]

[DB2-B7740]

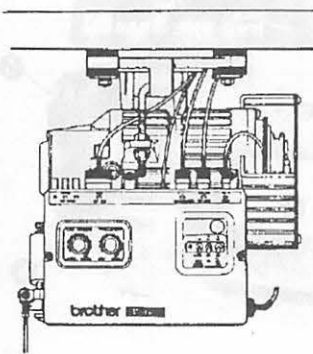
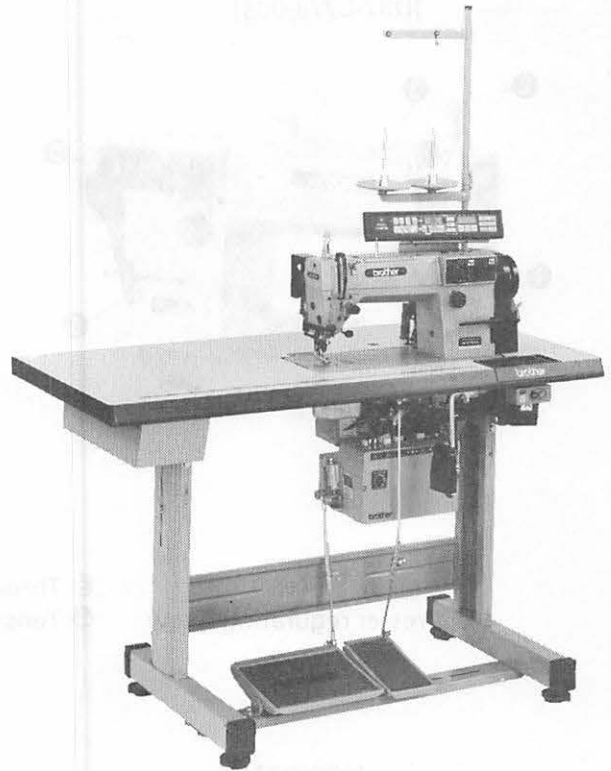
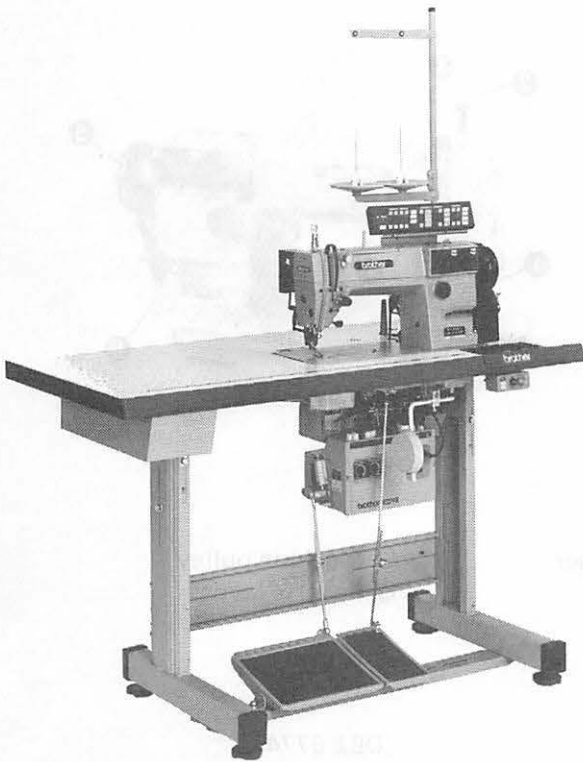

Motor

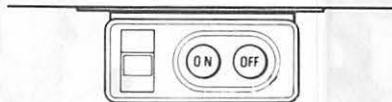

Power switch

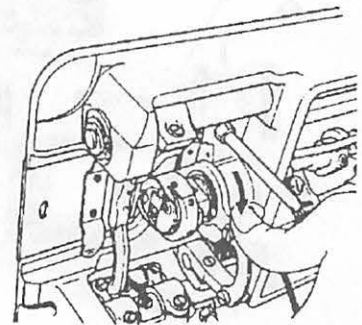

Thread trimmer

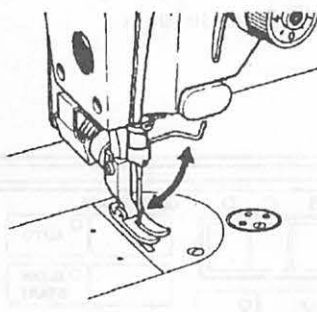

Thread wiper

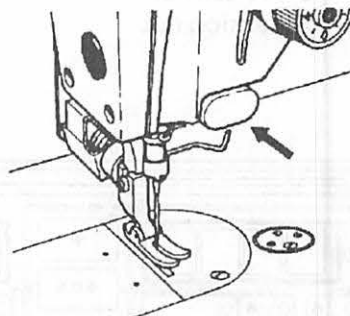

Quick reverse  
Compensation sewing

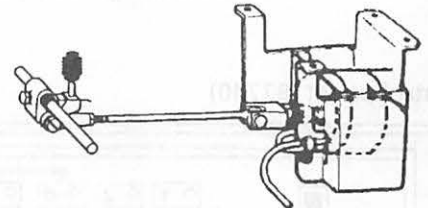

Automatic presser bar lifter

# SPECIFICATIONS

BROTHER INDUSTRIES, LTD.

DB2-B773-00□

MADE IN JAPAN

When the upper feed amount is 6 mm or more, or When the lower feed amount is 4 mm or more, use a sewing speed less than 3500 spm.

Use a maximum feed amount of less than 6 mm when a pucker type gauge (assembly A) or pucker-control gauge (assembly C) is used on model DB2-B772-006.

		-003	-006
Use		Medium material	Gathering
Sewing speed		4,500 spm	
Maximum Stitch length		5 mm	
Maximum upper feed amount		6 mm	8 mm
Presser foot height	Presser bar lifter	6 mm	
	Knee lifter	13 mm	
Feed dog height		0.8 mm	
Needle DB x 1		# 11	
Gauge		Assembly S	Assembly B
Shirring device		Included	

The specifications of DB2-B774 with automatic thread trimmer are shown below.

BROTHER INDUSTRIES, LTD.

DB2-B774-■ ■ ■

MADE IN JAPAN

	-30	-40	-90
Thread trimmer	○	○	○
Thread wiper	/	○	○
Quick back	○	○	○
Automatic presser bar lifter	/	/	○
Ply sensor	Option		
Control panel	E20, E40, E100 (option)		

When the upper feed amount is 6 mm or more, or When the lower feed amount is 4 mm or more, use a sewing speed less than 3500 spm.

		-003	-006
Use		Medium material	Gathering
Sewing speed		4,500 spm	
Maximum upper feed amount		6 mm	8 mm
Feed dog height		0.8 mm	
Presser foot height	Presser bar lifter	6 mm	
	Knee lifter	13 mm	
	Automatic presser bar lifter	6 mm	
Needle DB x 1		# 11	
Gauge		Assembly S	Assembly B

Use a maximum feed amount of less than 6 mm when a pucker type gauge (assembly A) or pucker-control gauge (assembly C) is used on model DB2-B772-■06.

When the upper feed amount is 6 mm or more, or When the lower feed amount is 4 mm or more, use a sewing speed less than 3500 spm.

Use a maximum feed amount of 6 mm or less than 6 mm when a pucker type gauge (assembly A) or pucker-control gauge (assembly C) is used on model DB2-B772-□26.

DB2-B7740	-423	-923	-426	-926
Use	Medium material		Gathering	
Sewing speed	4,500 spm			
Maximum Stitch length	5 mm			
Maximum upper feed amount	6 mm		8 mm	
Presser foot height	Presser bar lifter		13 mm	
	Knee lifter		Minimum 10 mm	
	Automatic presser bar lifter		8 mm	
Feed dog height	0.8 mm			
Needle DB x 1	# 11			
Thread trimmer	○			
Thread wiper	○			
Quick back	○			
Automatic presser bar lifter	/	○	/	○

Optional equipment

Control panel

E -20

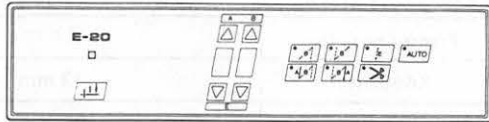

E -40

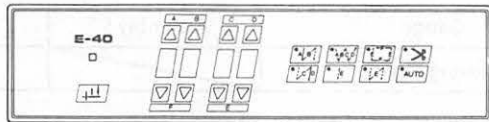

E -100

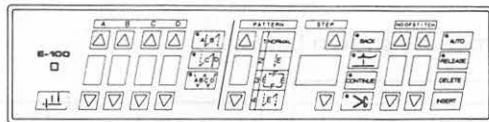

Ply sensor

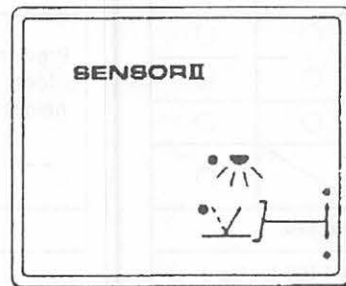
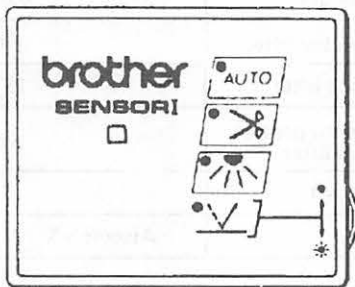

Piece counter

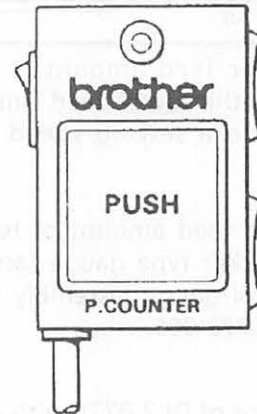

The control panels are optional. Use one that suits your operation.

Perspective

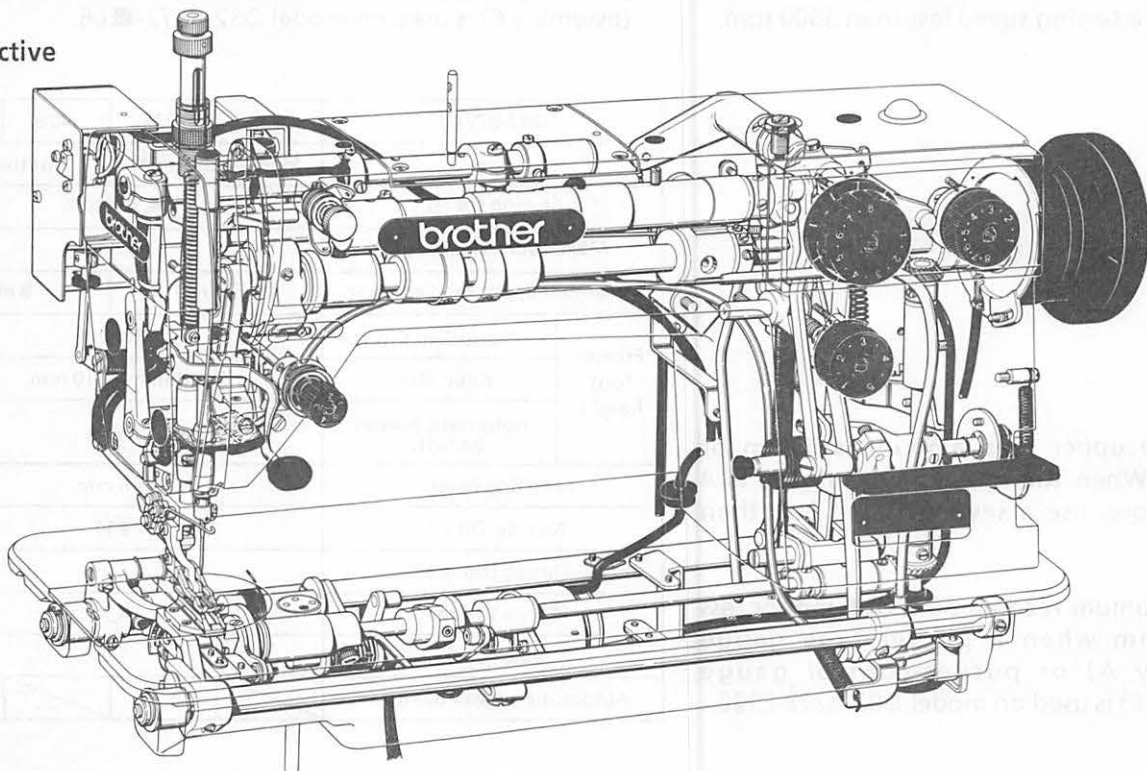

## MECHANICAL DESCRIPTIONS

### 1 Upper shaft and needle bar mechanism

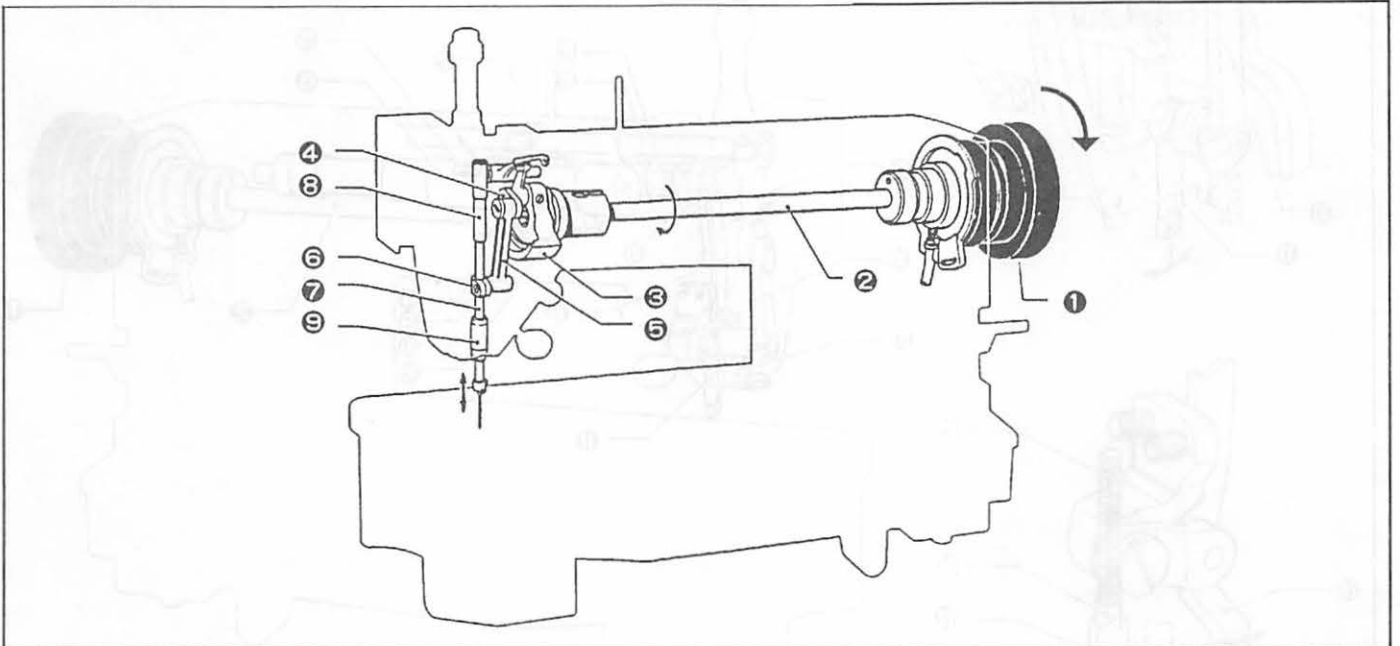

- 1) Turning the machine pulley ① rotates the upper shaft ②, which in turn causes the thread take-up crank ③ to rotate.
- 2) The thread take-up lever assembly ⑤ is driven via the needle bar crank ④ attached to the thread take-up crank ③.
- 3) The needle bar ⑦, attached to the needle bar clamp ⑥, moves up and down.
- 4) The needle bar is guided by the needle bar bushings (upper) ⑧ and (lower) ⑨.

### 2 Lower shaft and rotary hook mechanism

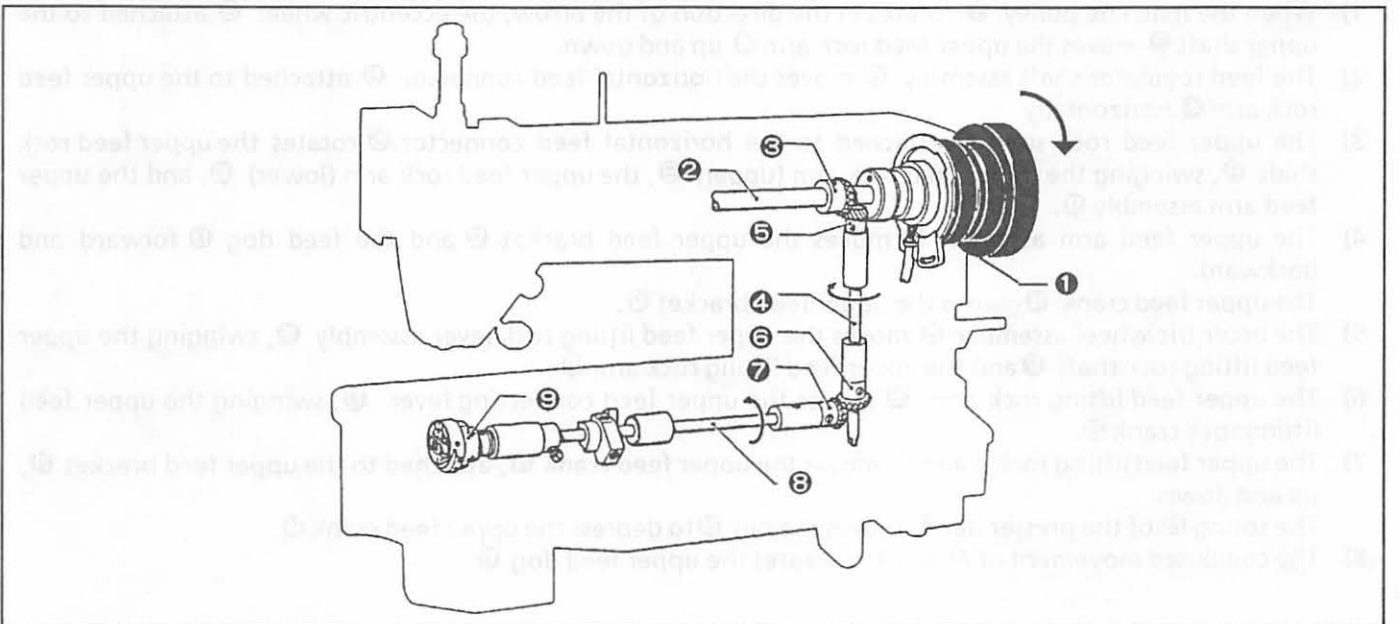

- 1) Rotation of the machine pulley ① is transferred from the upper shaft bevel gear ③ attached on the upper shaft ② to the vertical shaft bevel gear (upper) ⑤ attached on the top of the vertical shaft ④.
- 2) The motion is relayed from the vertical shaft bevel gear (lower) ⑥ attached on the bottom of the vertical shaft ④ to the lower shaft via the lower shaft bevel gear ⑦.
- 3) The rotary hook ⑧ is driven in full revolutions by the lower shaft ③.



### 3 Upper feed mechanism

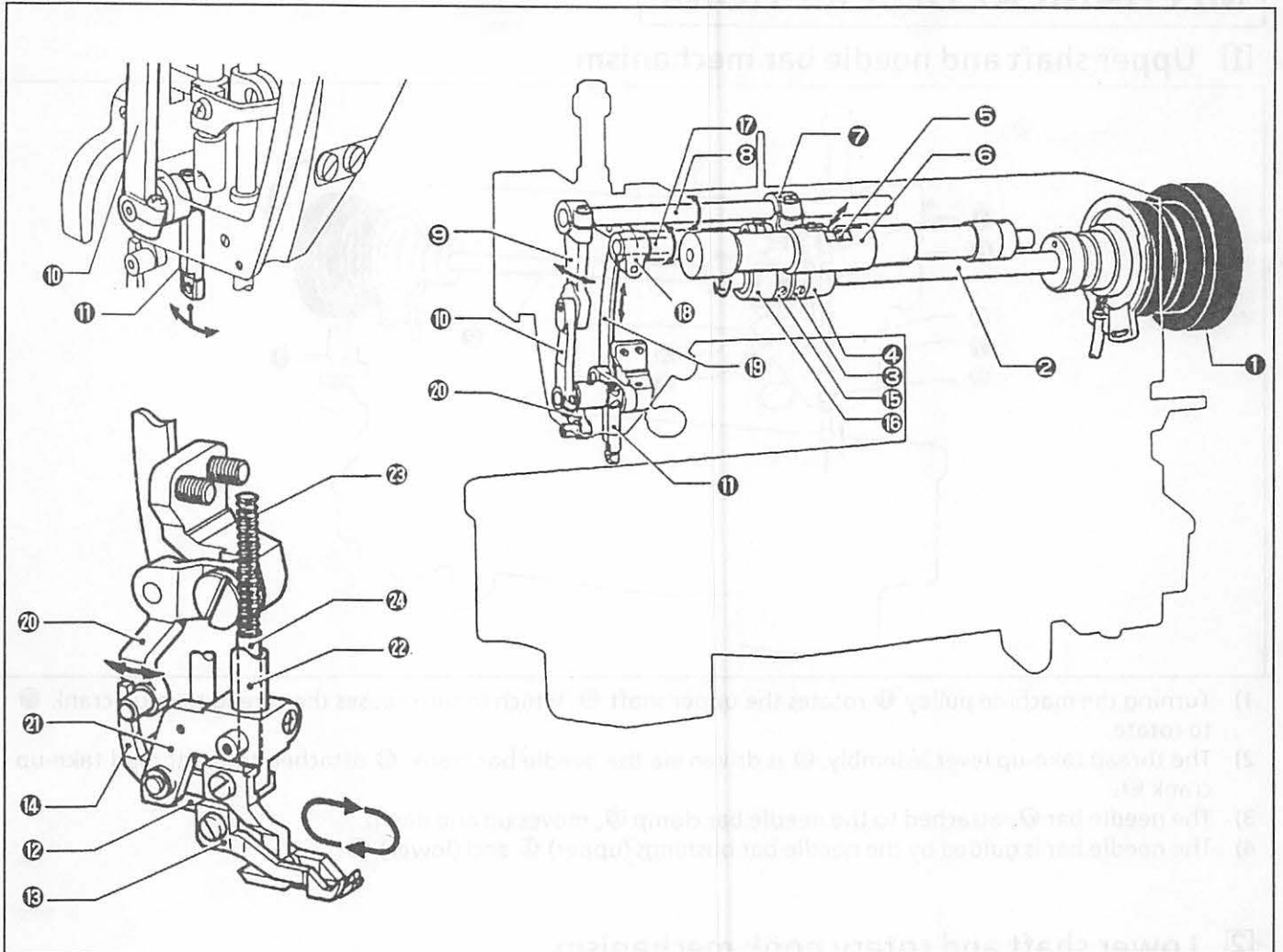

- 1) When the machine pulley ① rotates in the direction of the arrow, the eccentric wheel ③ attached to the upper shaft ② moves the upper feed rock arm ④ up and down.
- 2) The feed regulator shaft assembly ⑥ moves the horizontal feed connector ⑤ attached to the upper feed rock arm ④ horizontally.
- 3) The upper feed rock shaft ⑦ attached to the horizontal feed connector ⑤ rotates the upper feed rock shaft ⑧, swinging the upper feed rock arm (upper) ⑨, the upper feed rock arm (lower) ⑩, and the upper feed arm assembly ⑪.
- 4) The upper feed arm assembly ⑪ moves the upper feed bracket ⑫ and the feed dog ⑬ forward and backward.  
The upper feed crank ⑭ guides the upper feed bracket ⑫.
- 5) The eccentric wheel assembly ⑮ moves the upper feed lifting rock lever assembly ⑯, swinging the upper feed lifting rock shaft ⑰ and the upper feed lifting rock arm ⑱.
- 6) The upper feed lifting rock arm ⑱ moves the upper feed connecting lever ⑲, swinging the upper feed lifting rock crank ⑳.
- 7) The upper feed lifting rock crank ⑳ moves the upper feed crank ⑭, attached to the upper feed bracket ⑫, up and down.  
The spring ㉔ of the presser bar ㉒ moves the pin ㉓ to depress the upper feed crank ⑭.
- 8) The combined movement of 4) and 7) operates the upper feed dog ⑬.

#### 4 Feed mechanism

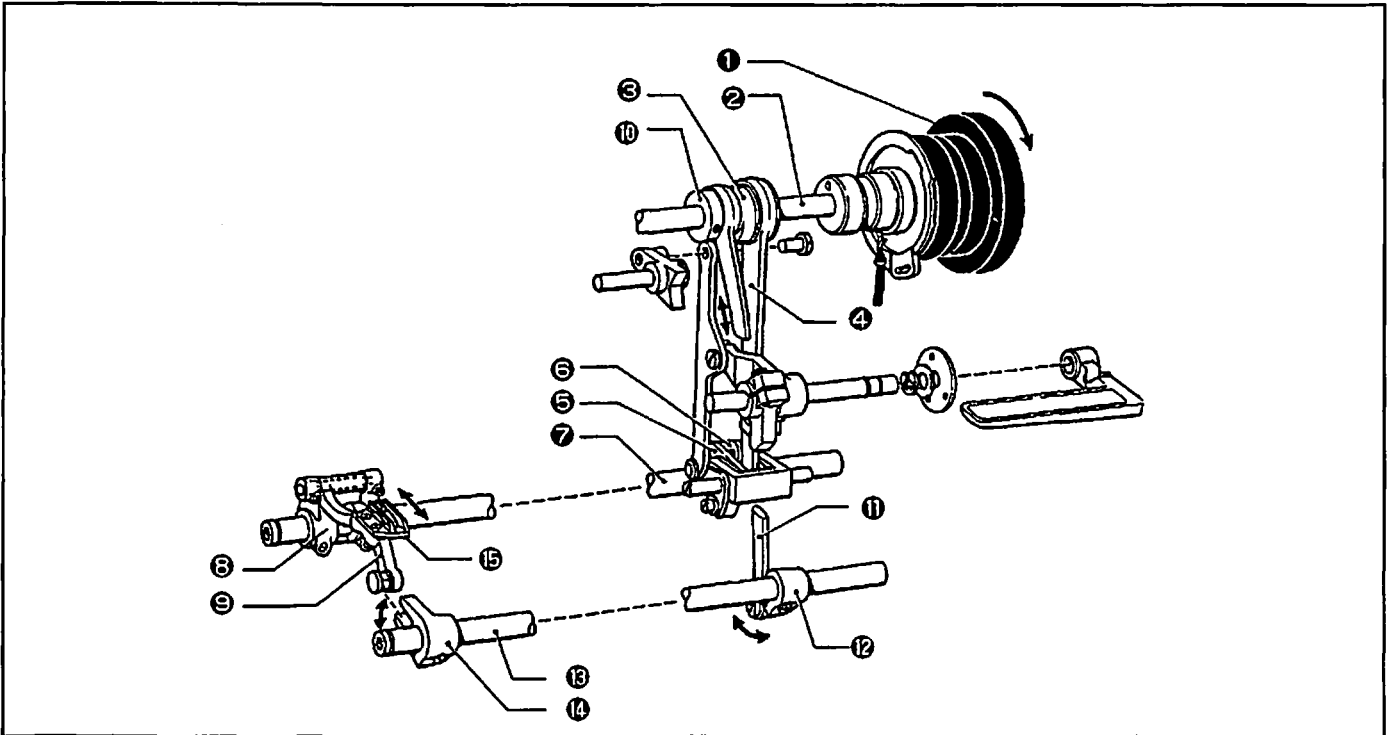

- 1) When the machine pulley ① rotates in the direction of the arrow, the level feed eccentric wheel ③ attached to the upper shaft ② moves the level feed connecting dog ④ up and down.
- 2) The level feed connecting dog ④ moves the level feed arm link assembly ⑤, swinging the feed rock shaft arm ⑤.
- 3) The feed rock shaft arm ⑤ moves the feed rock shaft ⑦.
- 4) The feed rock shaft ⑦ moves the horizontal feed bracket arm ⑧, moving the feed bracket ⑨ forward and backward.
- 5) The eccentric wheel ⑩ moves the vertical feed connecting rod ⑪ up and down.
- 6) The vertical feed connecting rod ⑪ swings the feed lifting rock shaft crank ⑫ attached to it.
- 7) The feed lifting rock shaft crank ⑫ moves the feed lifting rock shaft ⑬.
- 8) The feed lifting rock shaft ⑬ moves the feed lifting crank ⑭, moving the feed bracket ⑨ up and down.
- 9) The combined movement of 4) and 8) operates the feed dog ⑮ attached to the feed bracket ⑨.

## 5 Feed adjusting mechanism and quick reverse mechanism

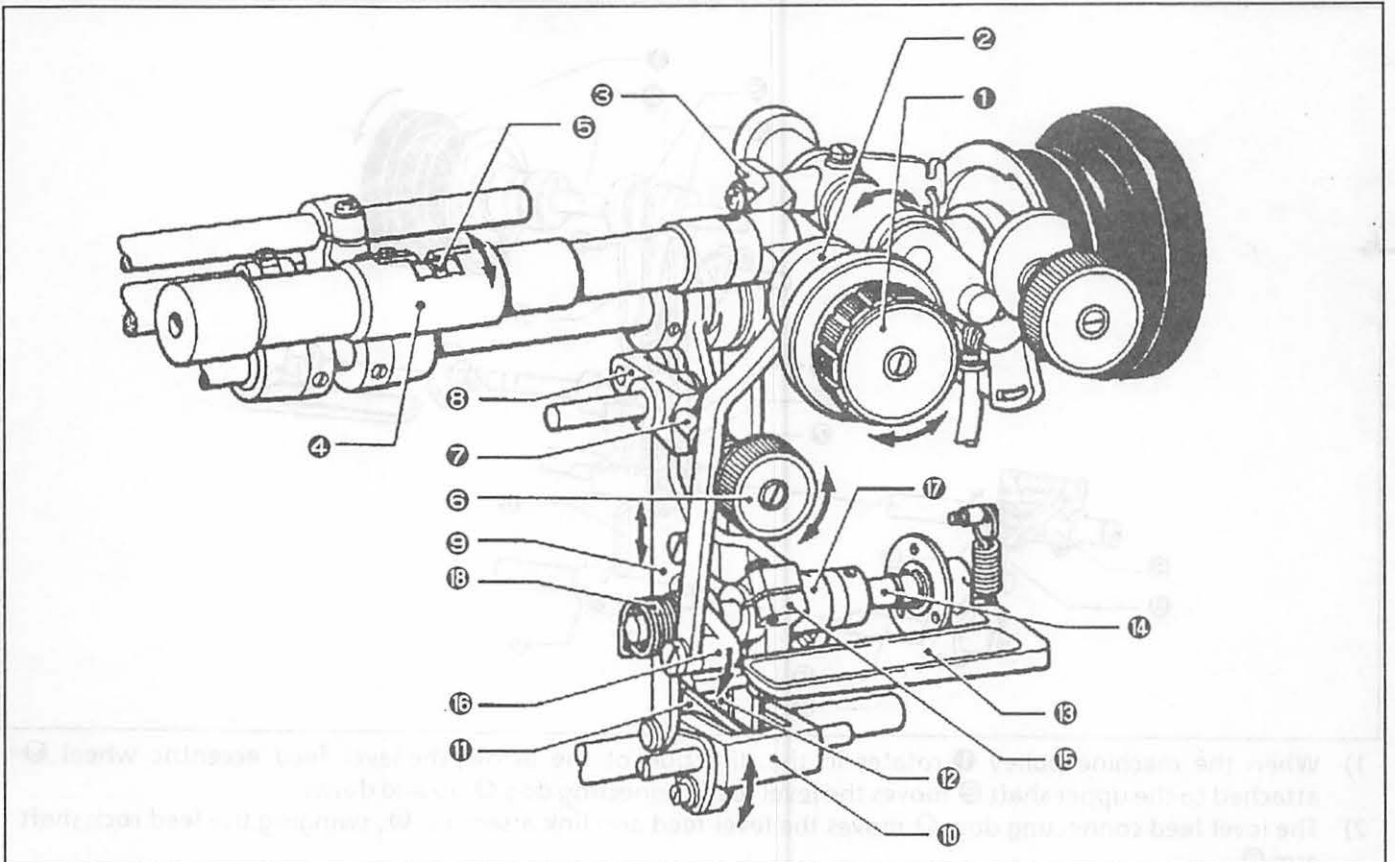

### The upper feed regulating plate assembly

- 1) When the upper feed regulating plate assembly ① rotates, the upper feed regulator cam ② rotates, moving the upper feed regulator assembly ③.
- 2) The angle of the feed regulator shaft assembly ④ attached to the upper feed regulator assembly ③ changes, changing the range of the movement of the horizontal feed connector ⑤.
- 3) For the movement after the horizontal feed connector ⑤, see page 6 "3 Upper feed mechanism". Rotating the upper feed regulating plate assembly ① changes the upper feed amount.

### The length control assembly

- 1) When the length control assembly ⑥ rotates, the feed regulator screw ⑦ moves forward and backward, moving the feed regulator ③.
- 2) The feed regulator ③ moves the level regulator connecting rod assembly ⑧, changing the angle of the feed regulator ⑩. Then the fulcrum of the arm link assembly ⑪ moves, changing the range of the movement of the feed rock shaft arm ⑫.
- 3) For the movement after the feed rock shaft arm ⑫, see page 7 "4 Feed mechanism". Rotating the length control assembly ⑥ changes the feed amount.

### The quick reverse mechanism

- 1) When the reverse lever ⑬ is depressed, the feed regulator lever ⑮, the feed regulator lever (lower) ⑯ linked with the reverse lever shaft ⑭ moves.
- 2) The feed regulator lever ⑮ moves the feed regulator lever (upper) ⑰ and the feed regulator lever (lower) ⑯ to shift back the feed regulator shaft assembly ④ and the feed regulator ⑩. Then the upper feed and the feed are reversed.
- 3) When the reverse lever ⑬ is pressed back, the upper feed reverse spring ⑱ changes the upper feed and the feed to the normal feed.

## 6 Upper feed mechanism and shirring mechanism (subclass -006)

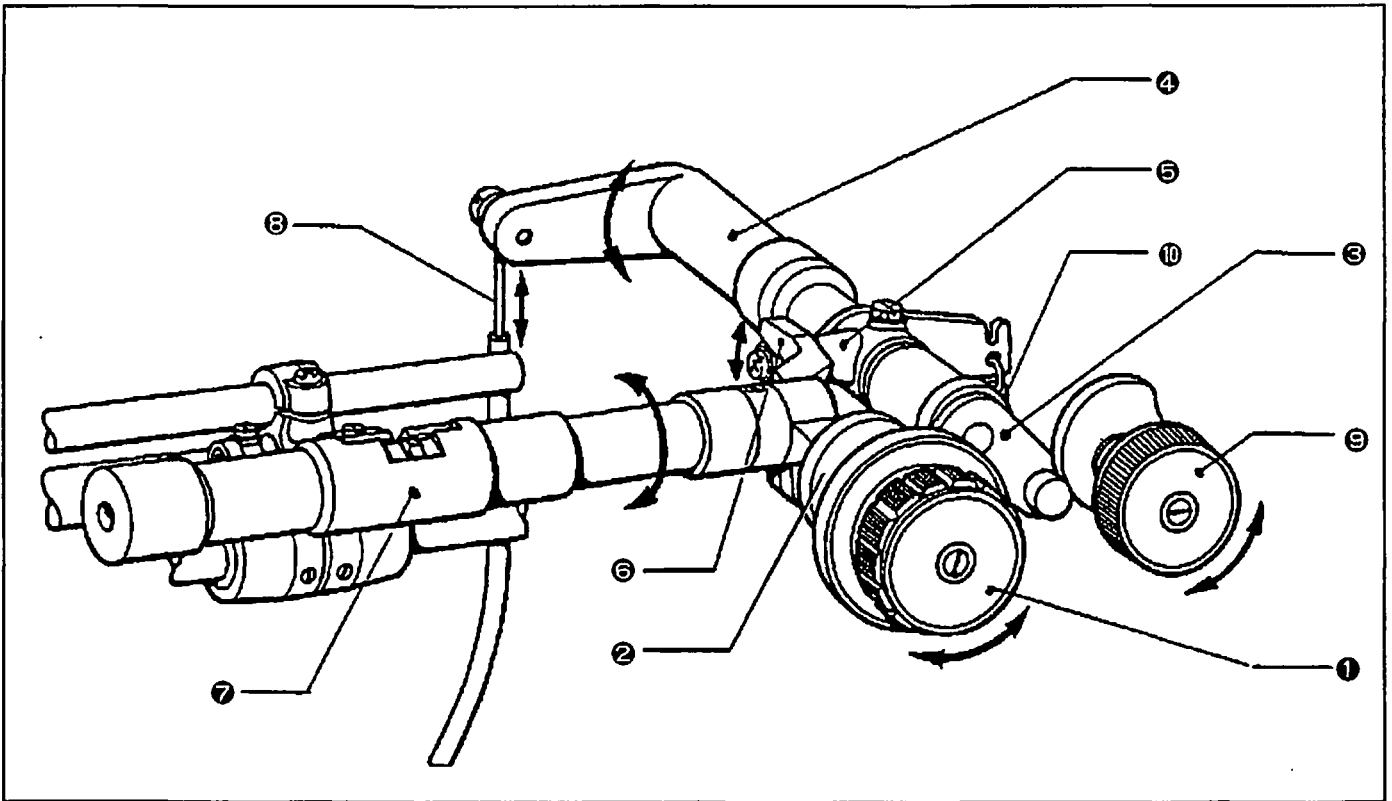

### Upper feed amount

- 1) When the upper feed regulating plate assembly (left) ① rotates, the upper feed regulator cam ② rotates, moving the shirring lever ④ linked with the upper feed regulator shaft ⑤.
- 2) The shirring lever ④ moves the upper feed regulator arm ⑥, moving the upper feed regulator assembly ⑦ and the feed regulator shaft assembly ⑧.  
Rotating the upper feed regulating plate assembly (left) ① changes the upper feed amount.

### Shirring

- 1) When the shirring wire ⑨ attached to the shirring lever ④ is pulled in the direction of the arrow, the shirring lever ④ moves the upper feed regulator shaft ⑤, the upper feed regulator arm ⑥, the upper feed regulator assembly ⑦, and the feed regulator shaft assembly ⑧.  
Rotating the upper feed regulating plate assembly (right) ③ changes the shirring amount.
- 2) When the shirring wire ⑨ is released, the spring ⑩ moves the shirring lever ④ and the upper feed regulator arm ⑥ to the previous positions.

## 7 Thread trimmer

### 1. Thread trimmer

The thread trimmer consists of the movable knife ①, the fixed knife ②, the lower thread finger ③, the movable knife holder ④, the knife holder presser ⑤, the forked shaft ⑥, the thread trimmer cam lever assembly ⑦, the thread trimmer clutch ⑧, and the thread trimmer solenoid ⑨.

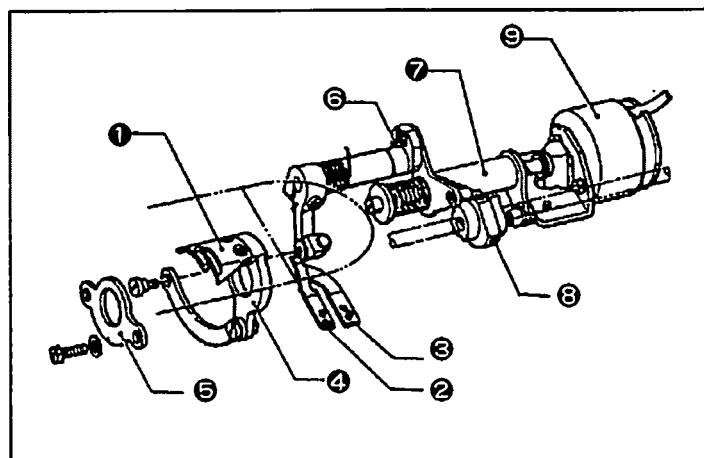

### 2. Thread trimmer operation (The five figures below and on the next page show the thread trimmer without the rotary hook assembly.)

#### (1) During operation

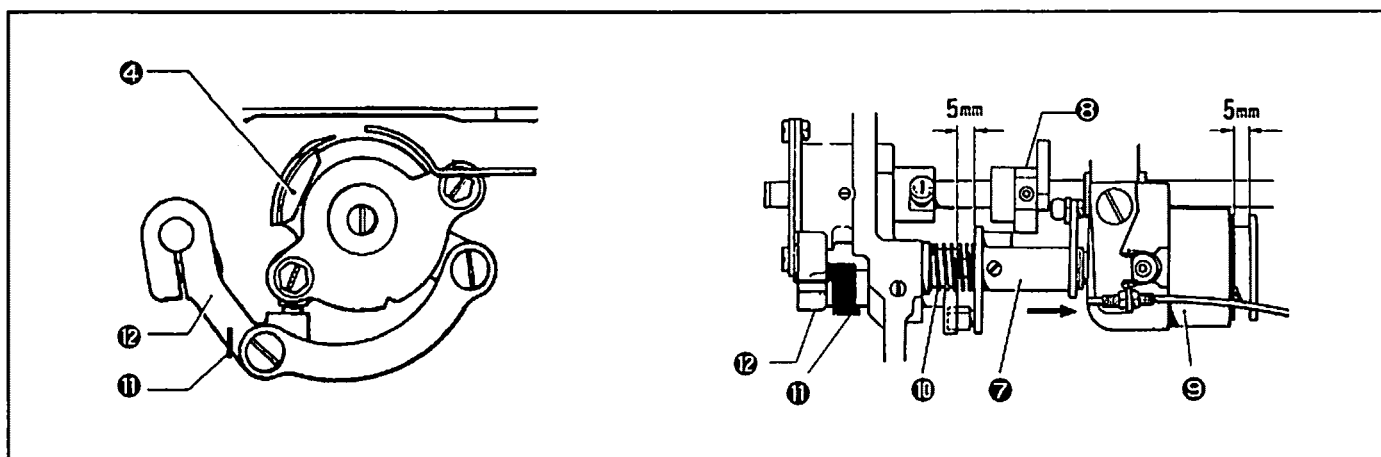

The thread trimmer cam lever spring ⑩ presses the thread trimmer cam lever assembly ⑦ against the thread trimmer solenoid ⑨. Because the thread trimmer cam lever assembly ⑦ does not engage with the thread trimmer clutch ⑧, the movable knife holder ④ does not function.

The thread trimmer lever spring ⑪ presses the thread trimmer lever ⑫ to prevent the movable knife holder ④ from shifting.

#### (2) When the thread trimming signal is received

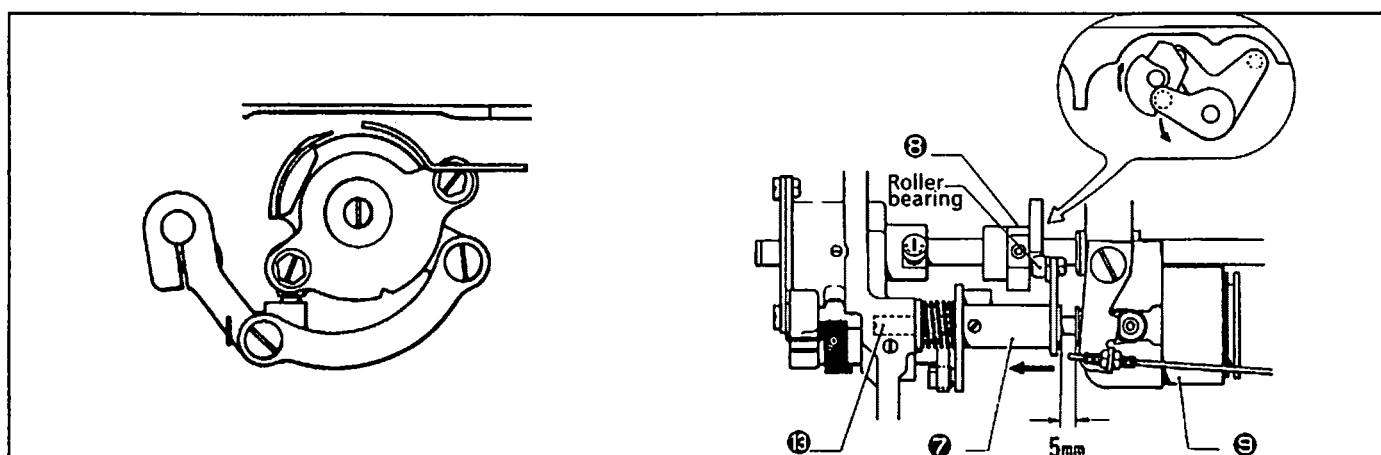

When the treadle is heeled back and the thread trimming signal is received, the thread trimmer solenoid ⑨ activates, and presses the thread trimmer cam lever stud ⑬. The roller bearing of the thread trimmer cam lever assembly ⑦, secured by the thread trimmer cam lever stud ⑬, is pushed above the circumference of the thread trimmer clutch ⑧.

(3) Movable knife holder action

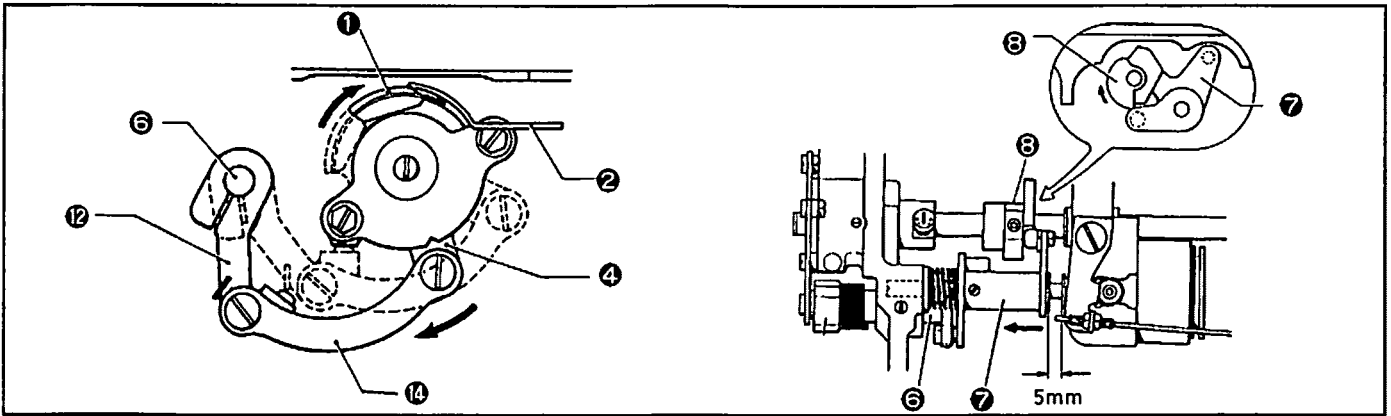

By the rotation of the lower shaft, the thread trimmer clutch ⑧ pushes the roller bearing up. The motion of the roller bearing is transmitted to the forked shaft ⑥ via the thread trimmer cam lever assembly ⑦. The motion is then relayed to the thread trimmer rod ⑭ and the movable knife holder ④ via the thread trimmer lever ⑫ connected to the forked shaft ⑥. The movable knife ① attached to the movable knife holder ④ moves in the direction of the arrow and overlaps the fixed knife ②.

(4) Thread trimming complete stop

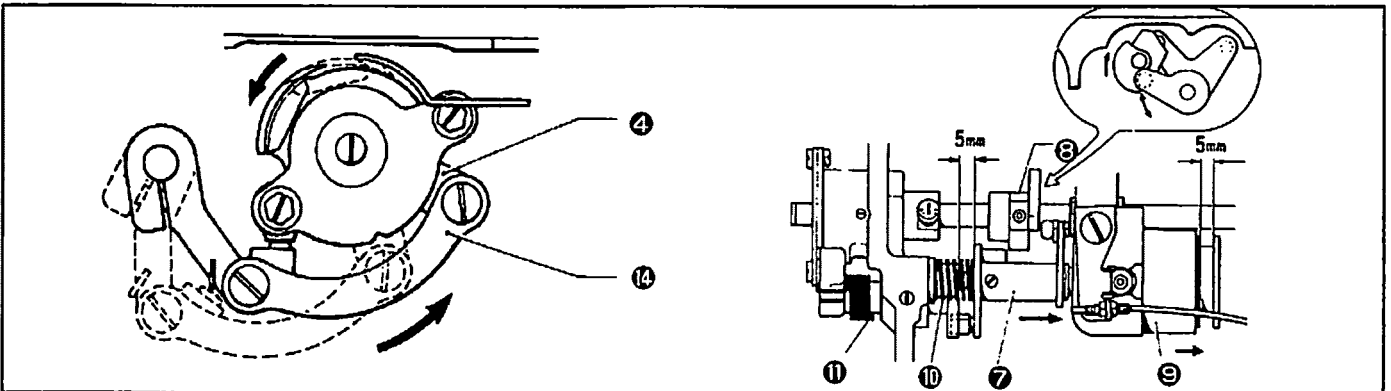

When the thread trimming signal is not received, the thread trimmer solenoid ⑨ retracts and the thread trimmer cam lever spring ⑩ pushes the thread trimmer cam lever assembly ⑦. Then the roller bearing of the thread trimmer cam lever assembly ⑦ moves away from the thread trimmer clutch ⑧ and returns to its original position. The thread trimmer lever spring ⑪ returns the thread trimmer rod ⑭ and the movable knife holder ④ to their original positions (in the direction of the arrow).

(5) Thread trimming safety device

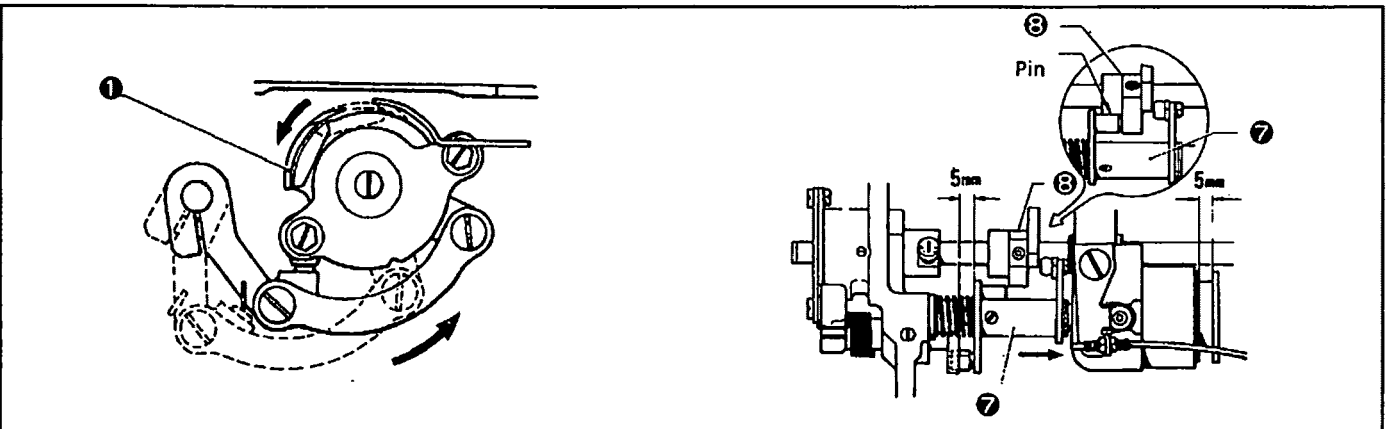

If the movable knife ① does not completely retract, the pin of the thread trimmer cam lever assembly ⑦ and the thread trimmer clutch ⑧ automatically carry the movable knife ① to a position where it does not strike the needle.

### 3. Needle and bobbin threads trimming

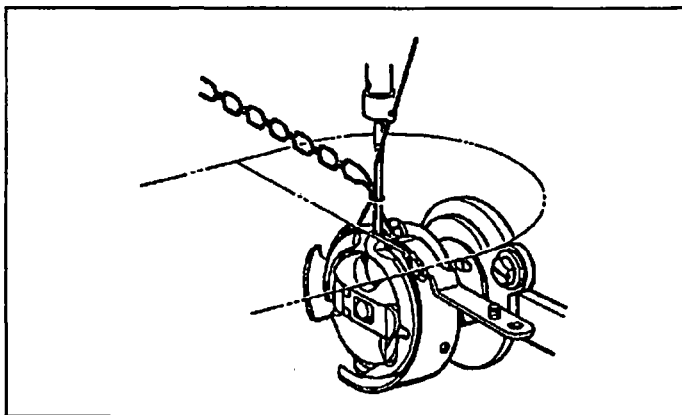

(1) When the needle rises 1.8 mm above its lowest position, the rotary hook point catches the loop formed by the needle.

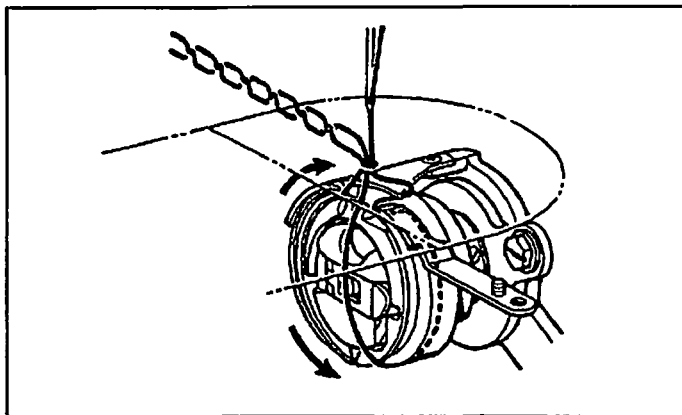

(2) When the thread trimming signal is received, the thread trimmer clutch drives the movable knife. The needle thread is caught by the rotary hook and fed around the shuttle body.

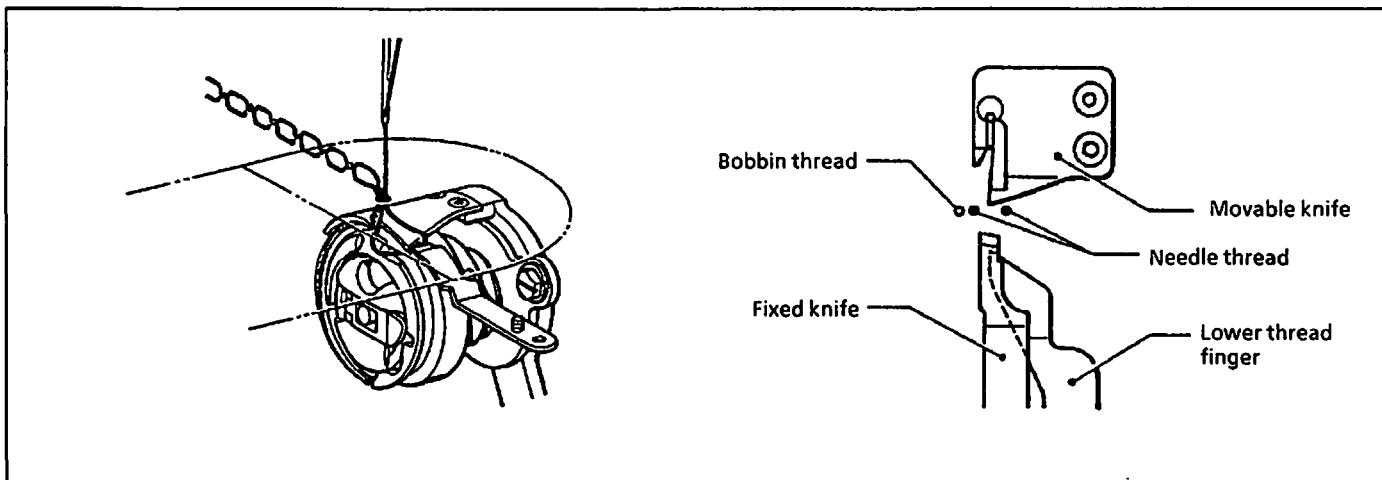

(3) The movable knife tip enters the triangular loop formed by the rotary hook point under the needle plate, and the loop spreading occurs. At this point the thread take-up is raised slightly above its lowest position (the upper shaft has turned approximately 330°), and the needle thread is spread by the movable knife as shown in the figure above.  
If the timing of the movement is too early, loop spreading is not performed properly which results in thread trimming errors.

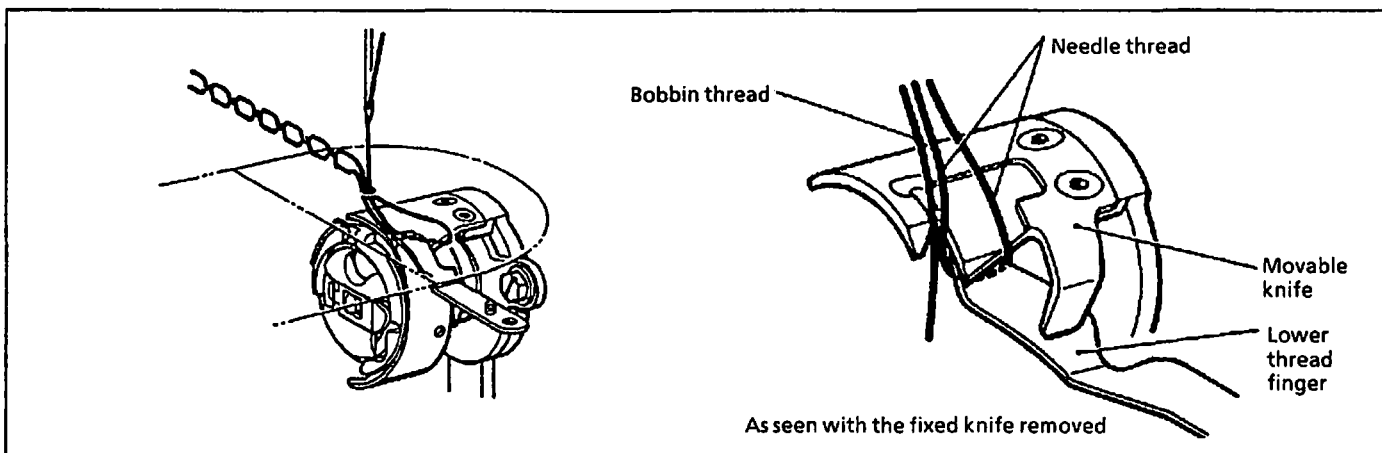

(4) The needle and bobbin threads caught by the movable knife in step (3) are gradually spread by the movable knife and the lower thread finger to be cut by the fixed knife tip. At this time, the thread take-up approaches the top of its stroke.  
When the movable knife is spreading the needle thread, the tension release relieves the needle thread tension to prevent excessive tension and to enable the needle thread to be extended smoothly.

## 8 Tension release

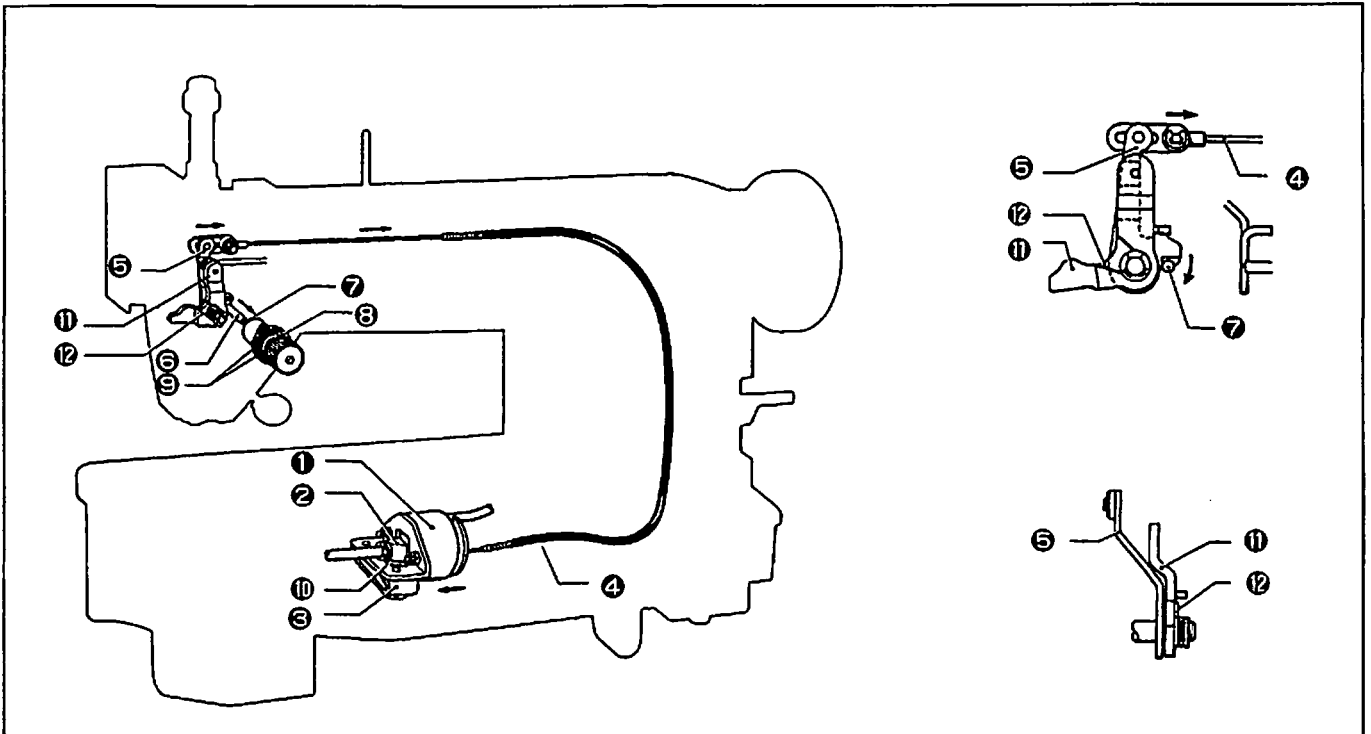

- 1) The thread trimmer solenoid ① operates when the thread trimming signal is received.
- 2) The solenoid lever ②, attached to the end of the thread trimmer solenoid ①, pushes the tension releasing lever ③.
- 3) The tension releasing wire ④ relays the motion of the tension releasing lever ③ to the thread tension releasing plate ⑤.
- 4) The thread tension releasing plate ⑤ presses the tension releasing stud ⑥.
- 5) The tension releasing stud ⑥ presses up the tension release pin ⑦ and the tension disc presser ⑧.
- 6) The tension disc presser ⑧ presses up the tension discs ⑨.
- 7) When the thread trimming signal is not received, the solenoid lever ②, the tension releasing lever ③ and the tension releasing wire ④ return to their original positions.

(The tension releasing spring ⑩ forces the tension releasing lever ③ all the way back.)

NOTE: When the presser foot is raised by the knee lifter, the knee lifter lifting lever ⑪ presses the thread tension releasing plate ⑤. The subsequent action is the same as steps 4 through 7 above.

When the presser foot is lowered, the presser lifter lever spring ⑫ returns the thread tension releasing plate ⑤ to its original position.

## 9 Thread wiper (subclasses -400, -900)

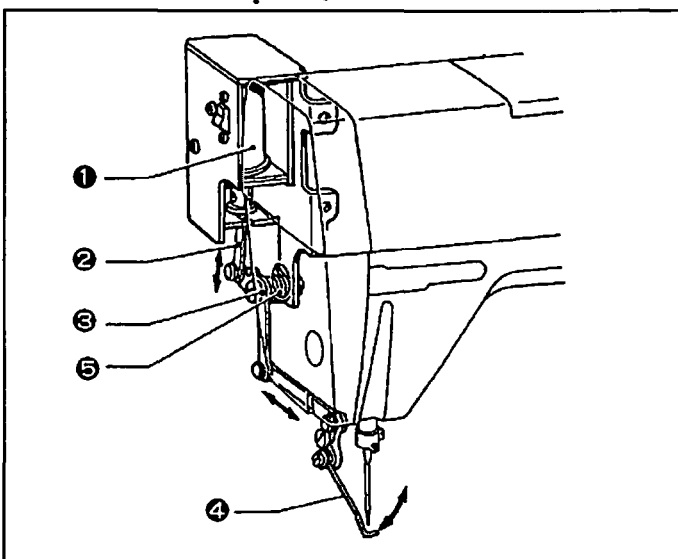

- 1) When the thread wiping signal is received after thread trimming is completed, the thread wiper solenoid ① lifts the thread wiper rod ②.
- 2) The thread wiper rod ② drives the thread wiper crank assembly ③, attached to the end of the thread wiper rod ②.
- 3) The thread wiper ④, attached to the end of the thread wiper crank assembly ③, wipes the thread.
- 4) When the thread wiper signal is not received, the thread wiper spring ⑤ returns the thread wiper solenoid ① to its original position.



## 10 Automatic presser bar lifter mechanism (subclass -900)

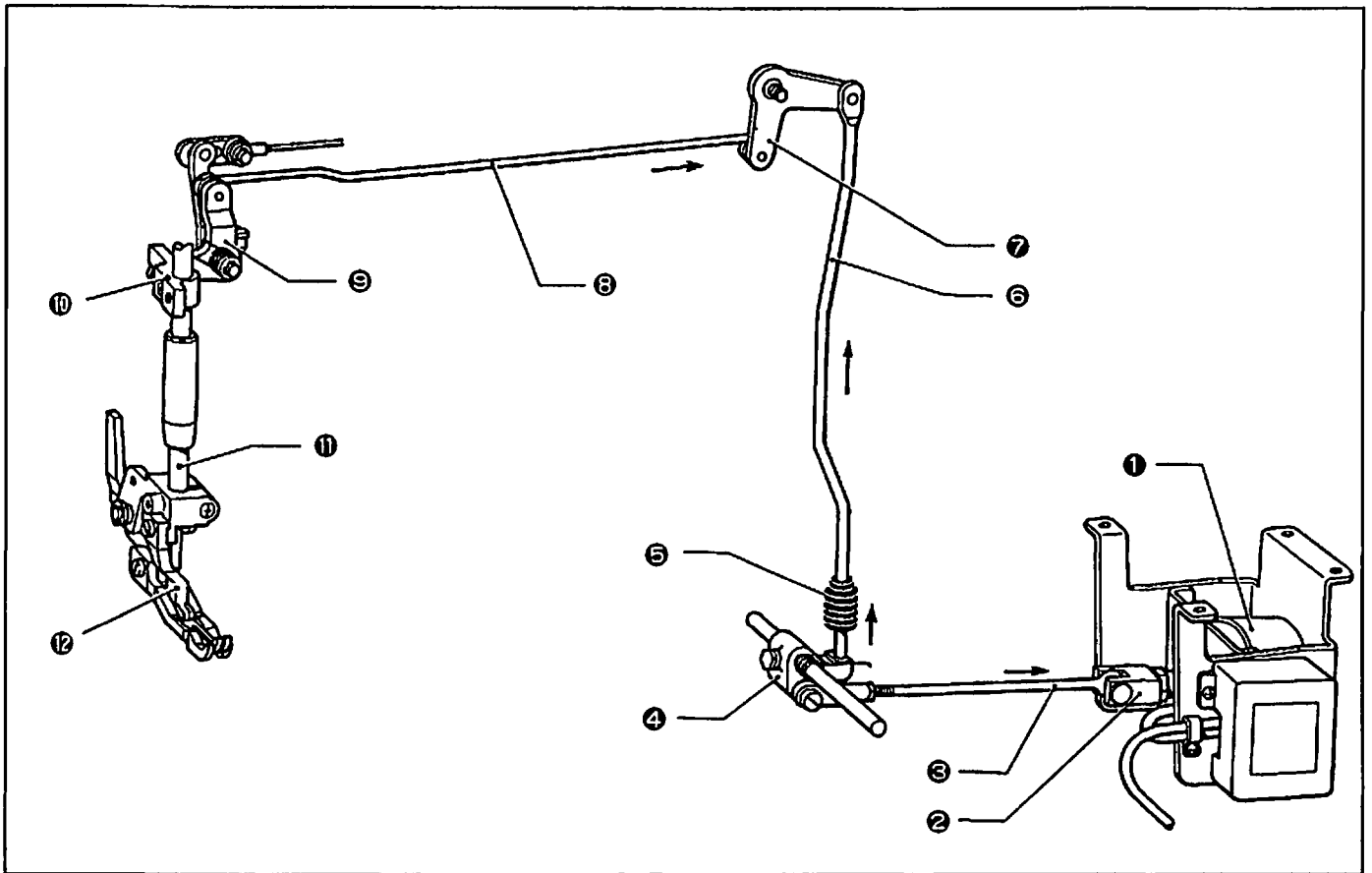

- 1) The presser foot lifting solenoid ① moves the link joint ② and the presser foot lifter regulating rod ③ when the knee switch is pressed.
- 2) The presser foot lifter regulating rod ③ pushes up the knee lifter complying bar ④ via the presser foot lifting link ④.
- 3) The knee lifter complying bar ④ moves up the presser bar clamp ⑨ via the knee lifter bar ⑧, the knee lifter lever ⑦, the knee lifter connector ⑥ and the knee lifter lifting lever ⑤.
- 4) The presser bar ⑩ and the presser foot ⑪, attached to the presser bar clamp ⑨, are lifted.

## 11 Lubrication mechanism

### 1. Upper shaft lubrication

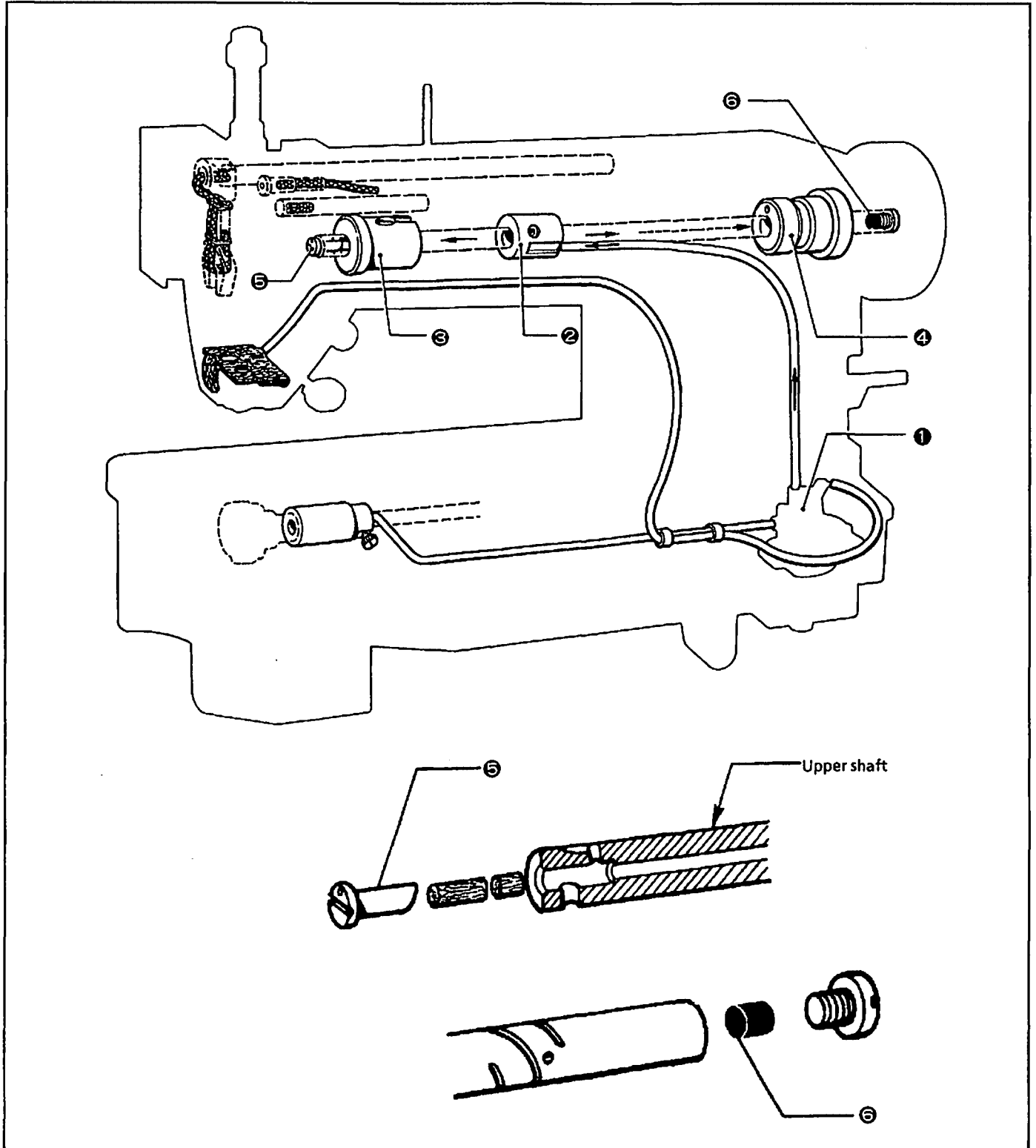

- 1) Oil fed by the pump body ① flows into the upper shaft through the upper shaft bushing (middle) ② to lubricate the upper shaft bushings (left) ③ and (right) ④. The oil sprayed inside the vertical portion of the body lubricates the feed regulator.
- 2) Because the oil regulating valve ⑤ is attached at the left edge of the upper shaft, the thread take-up body is lubricated through the thread take-up crank and the needle bar crank.
- 3) The thread take-up lever is lubricated through the felt attached to the needle bar crank. The felt prevents oil clogging and over-lubrication.
- 4) The oil cap ⑥ attached at the upper shaft's right edge prevents oil from being shed outside the machine.
- 5) The oil which is collected in the portion of the body with the needle mechanism is transported to the pump body ① via the felt and the wick.

## 2. Lower shaft lubrication

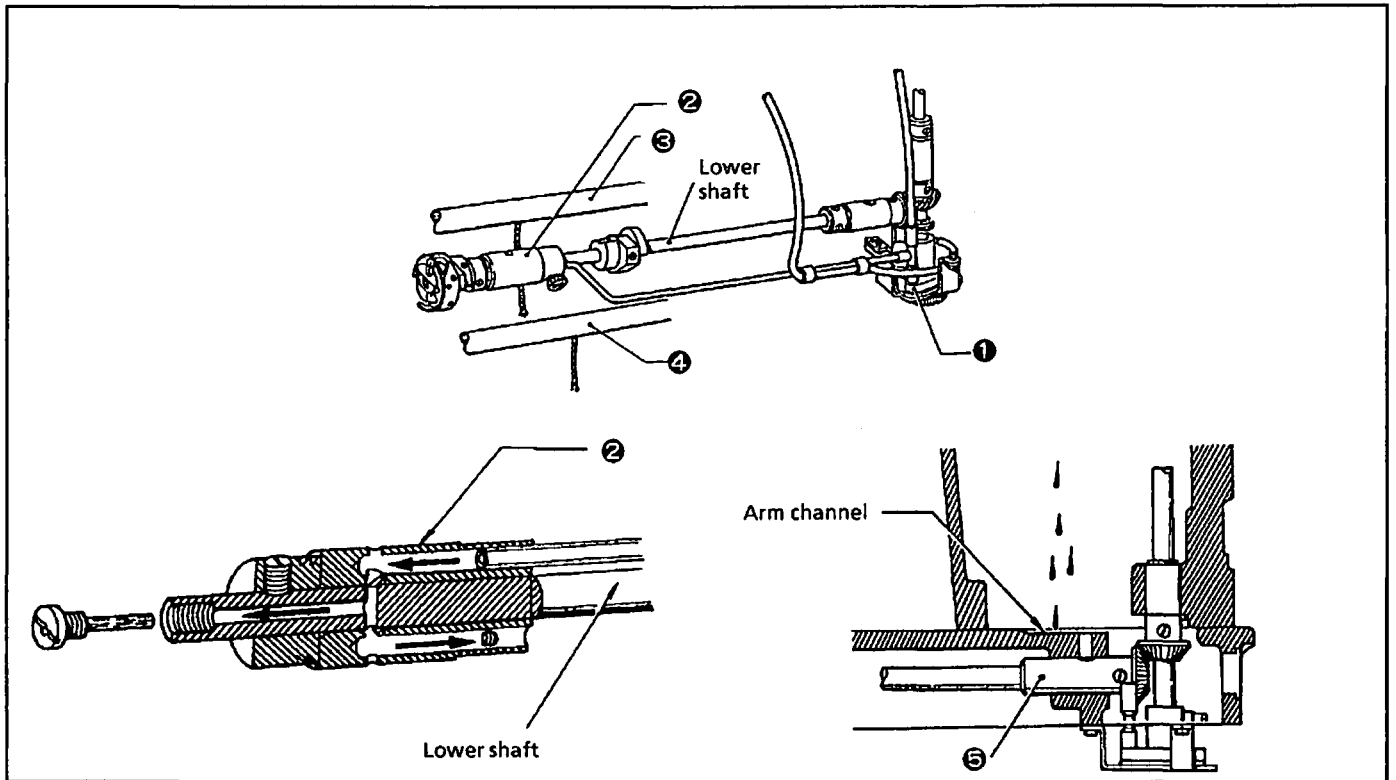

- 1) The oil fed by the pump ① lubricates the lower shaft and the lower shaft bushing (left) ②.
- 2) Some of the oil at the lower shaft bushing (left) ② flows through the lower shaft to lubricate the rotary hook.  
The oil shed from the lower shaft bushing (left) ② returns to the oil pan.
- 3) The oil absorbed by the wick lubricates the feed rock shaft ③ and the feed lifting rock shaft ④.
- 4) The oil sprayed inside the vertical portion of the body lubricates the lower shaft bushing (right) ⑤, the feed rock shaft ③ and the feed lifting rock shaft ④ through the arm channel.

## 3. Pump mechanism

By means of the rotation of the pump propeller ① attached at the vertical shaft bottom, oil is drawn to the pump through the center hole. The oil is fed to the lubrication tubes through the ports of the pump body.

The oil collected in the portion of the body ② with the needle mechanism is drawn to the pump body by the pump plunger.

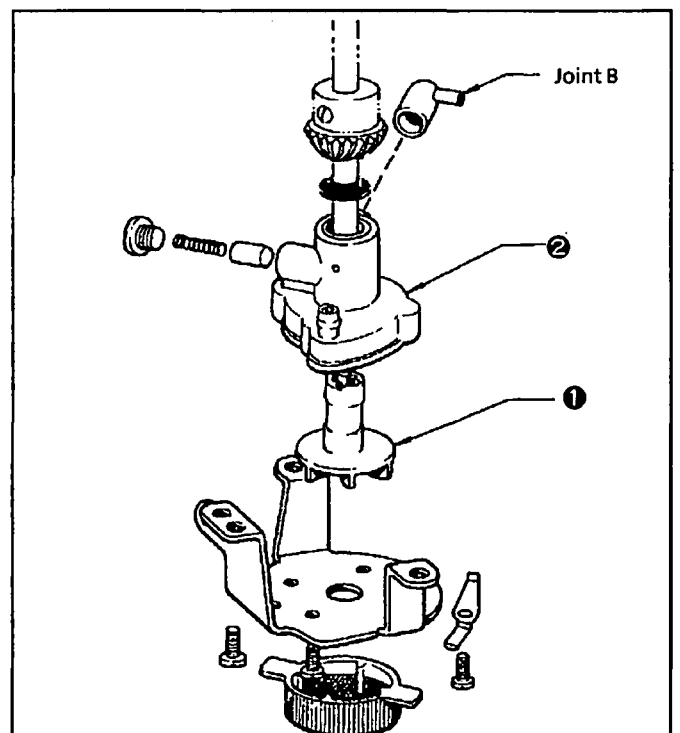

# DISASSEMBLY

## 1 Machine covers

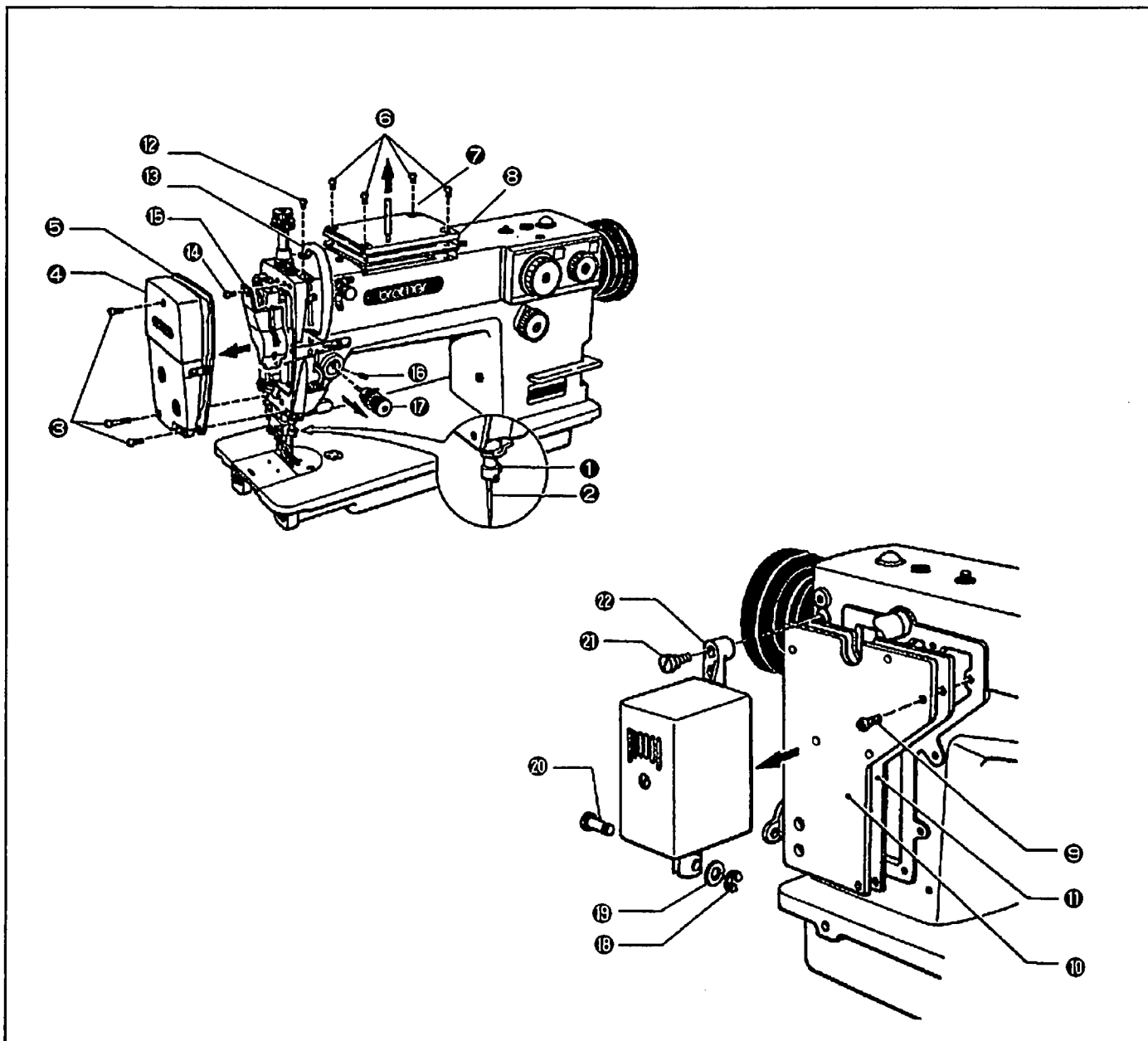

- 1) Remove the screw ① and the needle ②.
- 2) Remove the three screws ③, then remove the face plate ④ and the face plate packing ⑤.
- 3) Remove the four screws ⑥, then remove the upper cover ⑦ and the upper cover packing ⑧.
- 4) Remove the six screws ⑨, then remove the rear cover ⑩ and the rear cover packing ⑪.
- 5) Remove the screw ⑫ and the thread take-up cover ⑬.
- 6) Remove the two screws ⑭ and the oil stopper plate ⑮.
- 7) Remove the screw ⑯ and the upper tension regulator assembly ⑰.

For a sewing machine with automatic thread trimmer:

Before removing the rear cover ⑩, remove stop ring E ⑱, washer ⑲ and the connecting pin ⑳.

Remove the three screws ㉑ and the solenoid bracket ㉒.

## 2 Presser foot mechanism

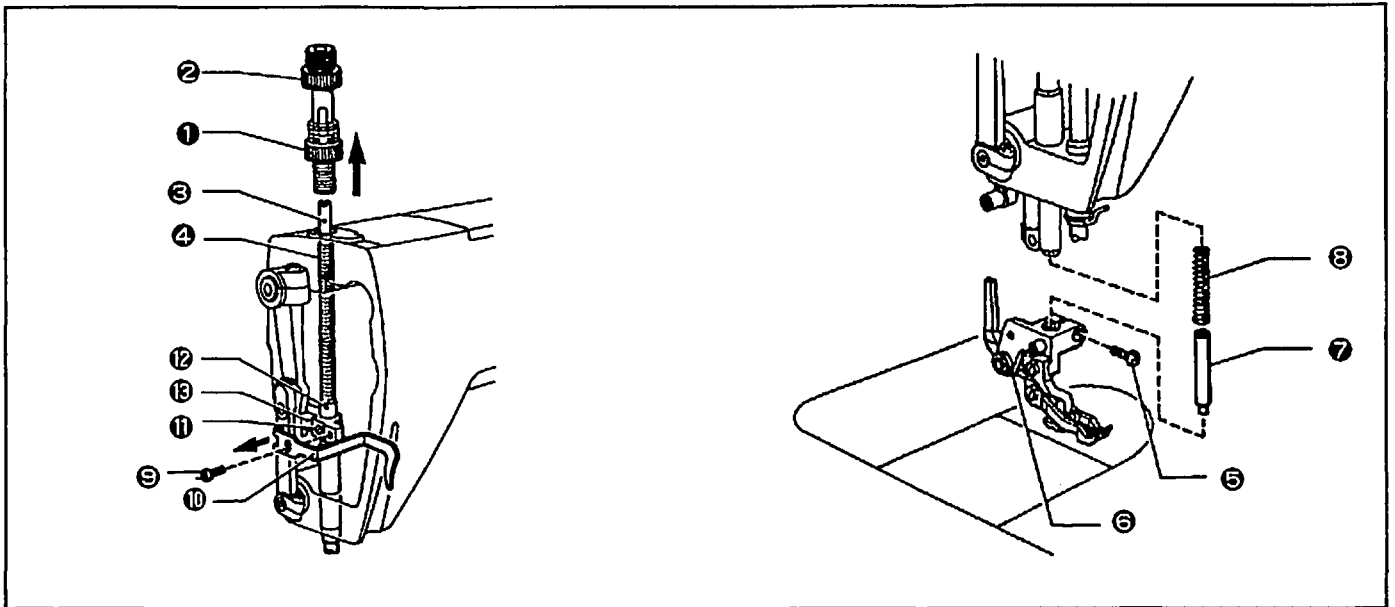

- 1) Remove the regulating nut ① and the presser regulating dial ②.
- 2) Remove the presser spring ④ and the adjusting screw ③.
- 3) Loosen the screw ⑤, and remove the upper feed bracket assembly ⑥ (presser foot, upper feed dog and upper feed crank).
- 4) Remove the the pin ⑦ and the spring ⑧.
- 5) Remove the screw ⑨ and the presser bar bracket thread guide ⑩.
- 6) Loosen the screw ⑪. Remove the presser bar clamp ⑬ by lowering the presser bar ⑫.
- 7) Remove the presser bar ⑫ from the arm top.

## 3 Upper feed mechanism

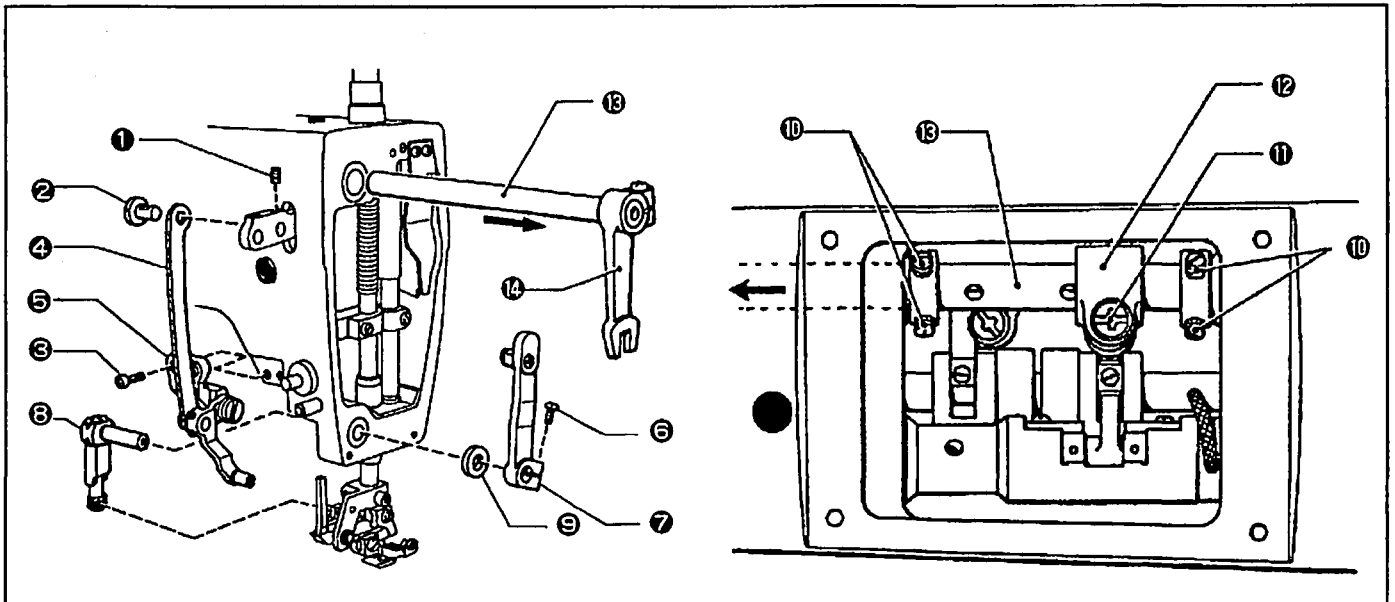

- 1) Loosen the screw ① and remove connecting stud (lower) ②.
- 2) Remove the two screws ③, then remove the upper feed connecting lever ④ and the crank assembly ⑤.
- 3) Loosen the screw ⑥. By inserting the screwdriver into the notch of the upper feed rock arm (lower) ⑦, remove the upper feed arm assembly ⑧ and the washer ⑨.
- 4) Loosen the four screws ⑩.
- 5) Loosen the screw ⑪. By inserting the screwdriver into the notch of the feed rock shaft ⑫, remove the upper feed rock shaft ⑬ and the upper feed rock arm (upper) ⑭.

#### 4 Rotary hook mechanism

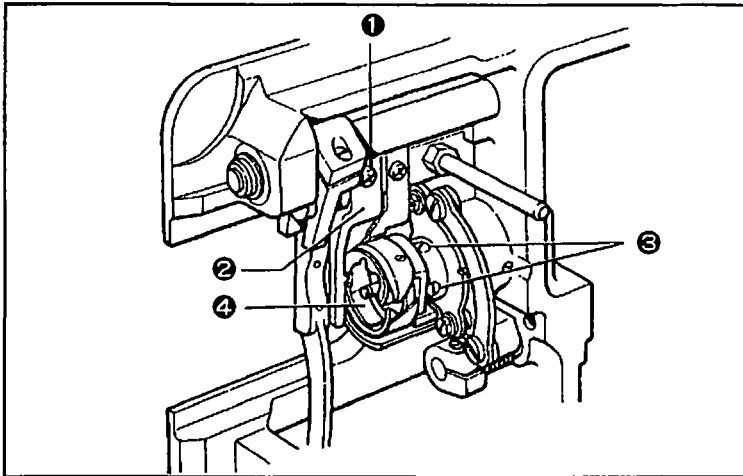

- 1) Tilt the machine head until it stops.
- 2) Remove the screw ① and the bobbin case holder position bracket ②.
- 3) Loosen the three screws ③ and remove the rotary hook assembly ④.

#### 5 Thread trimmer

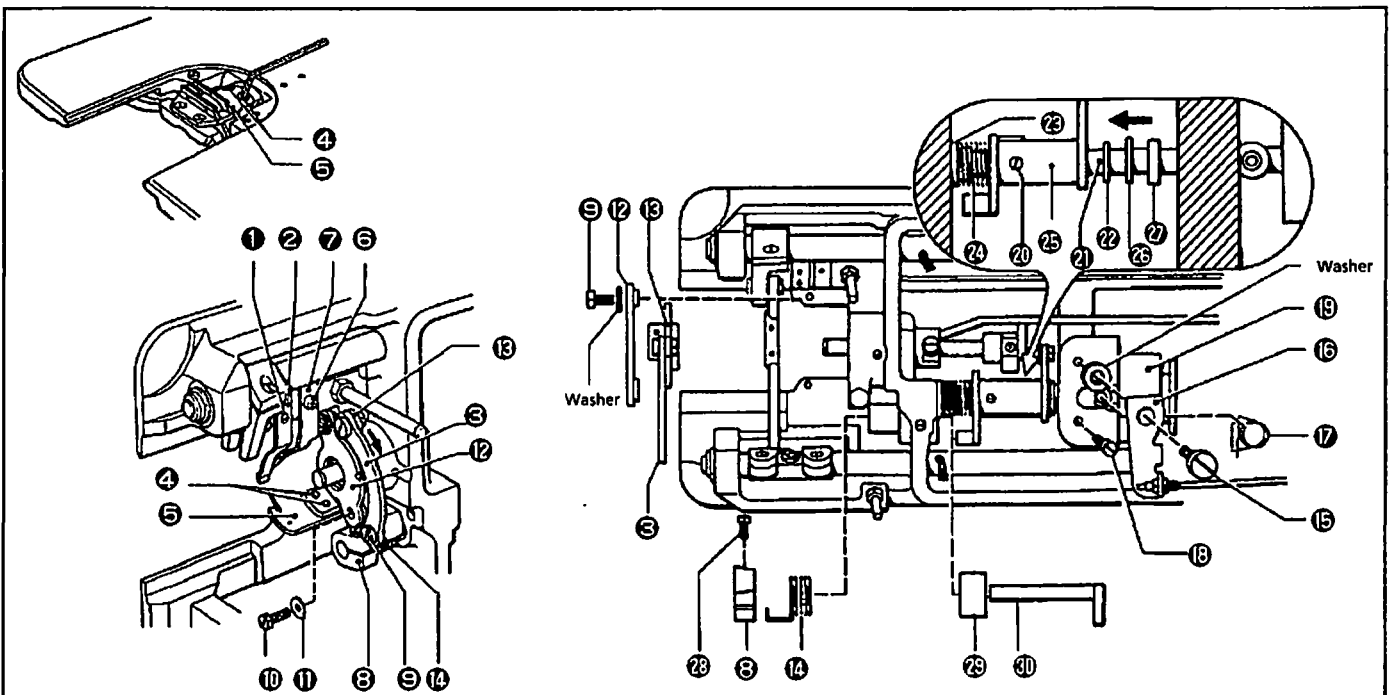

- 1) Remove the screw ① and the fixed knife ②.
- 2) Press the thread trimmer rod ③ in the direction of the arrow until the two screws ④ are visible.
- 3) Remove the screws ④ and the movable knife ⑤.
- 4) Remove the screw ⑥ and the lower thread finger ⑦.  
(B7740: Remove the reflector holder, the lower thread finger and the reflector.)
- 5) Remove the stud screw ⑧ securing both the thread trimmer lever ⑨ and the thread trimmer rod ③.
- 6) Remove the two bolts ⑩, the washer ⑪, the knife holder presser assembly ⑫, the movable knife holder ⑬ and the thread trimmer rod ③.
- 7) Remove the thread trimmer lever spring ⑭ from the thread trimmer lever ⑨.
- 8) Remove the stud screw ⑮, the tension release lever ⑯ and the tension release spring ⑰.
- 9) Remove the screw ⑱ and the thread trimmer solenoid ⑲.  
NOTE: When not removing the thread trimmer solenoid ⑲, tighten the screws ⑮ and ⑱ temporarily.
- 10) Loosen the screw ⑳ then remove the snap ring ㉒ by moving the thread trimmer cam lever stud ㉑ in the direction of the arrow.
- 11) Remove the thread trimmer cam lever stud ㉑ to the right (in the direction of the thread trimmer solenoid).
- 12) Remove the collar ㉓, the thread trimmer cam lever spring ㉔, the thread trimmer cam lever assembly ㉕, the washer ㉖ and the cushion ㉗.
- 13) Loosen the screw ㉘ then remove the thread trimmer lever ③, the thread trimmer lever spring ⑭, the collar ㉙ and the forked shaft ㉚.  
(To remove the thread trimmer solenoid, refer to page 47.)

## 6 Feed mechanism

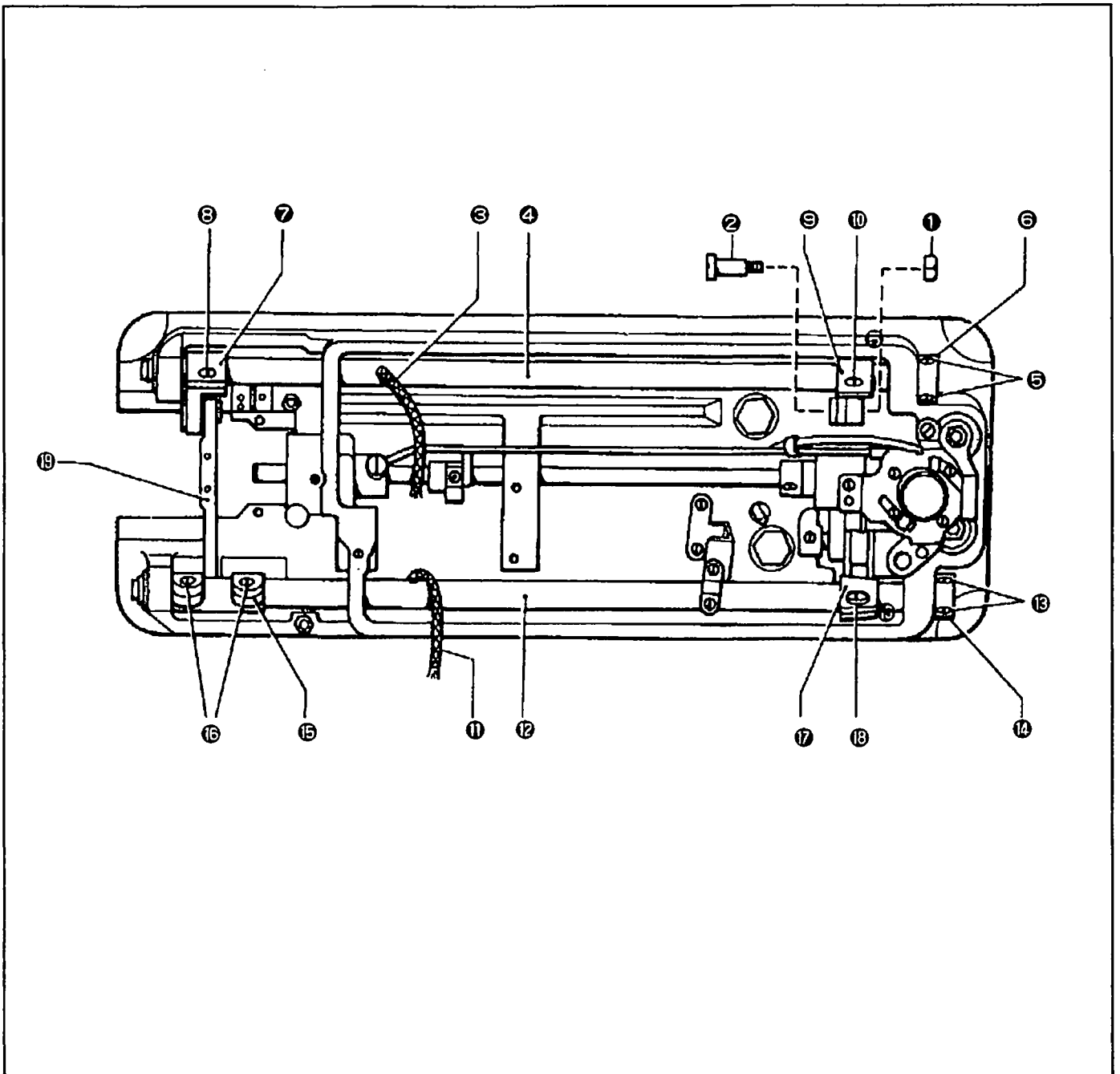

- 1) Loosen the nut ① and remove the stud screw ②.
- 2) Remove the wick ③ from the feed lifting rock shaft ④.
- 3) Loosen the two screws ⑤ and remove the set collar ⑥.
- 4) Loosen the screw ③ securing the feed lifting crank ⑦. Loosen the screw ⑩ of the feed lifting rock shaft crank ⑨.
- 5) By inserting a wedge (in Fig. A) into the notches of the feed lifting crank ⑦ and the feed lifting feed crank ⑨, remove the feed lifting rock shaft ④. (The feed lifting crank ⑦ and the feed lifting rock shaft crank ⑨ will come off.)
- 6) Remove the wick ⑪ from the feed rock shaft ⑫.
- 7) Loosen the two screws ⑬ and remove the set collar ⑭.
- 8) Loosen the two screws ⑮ of the horizontal feed bracket arm ⑮. Loosen the screw ⑯ of the feed rock shaft arm ⑰.
- 9) By inserting a wedge (in Fig. A) into the notches of the horizontal feed bracket arm ⑮ and the feed rock shaft arm ⑰, remove the feed rock shaft ⑫. (The horizontal feed bracket arm ⑮ will come off.) (The feed bracket assembly ⑱ is attached to the horizontal feed bracket arm ⑮.)

## 7 Needle bar mechanism

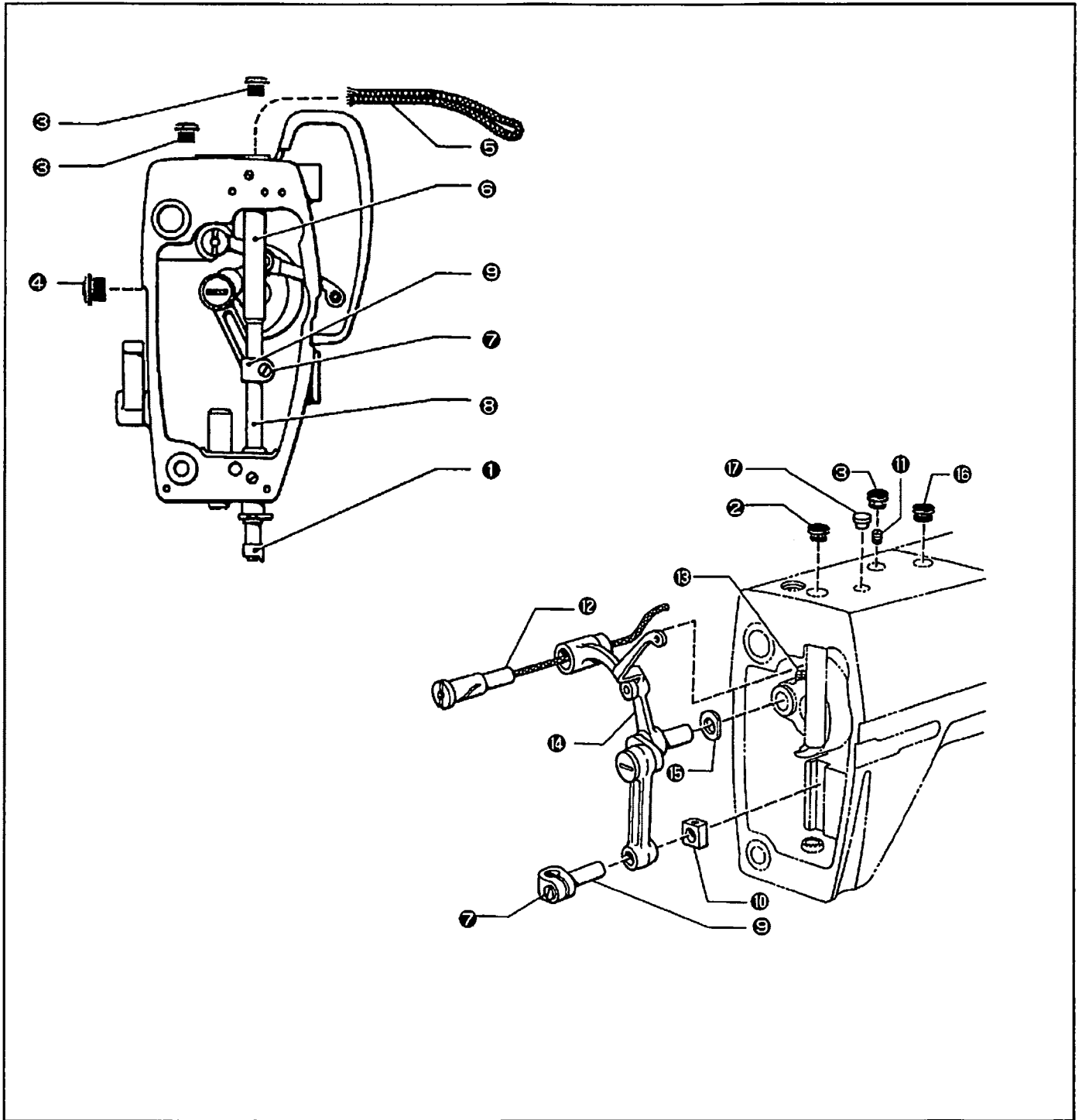

- 1) Raise the machine head.
- 2) Remove the needle bar thread guide ①.
- 3) Remove the oil caps ②, ③ and ④.
- 4) Remove the wick ⑤ from the top of the needle bar bushing (upper) ⑥.
- 5) Loosen the screw ⑦ then remove the needle bar ③ and the needle bar clamp ④. (The slide block ⑩ will come off.)
- 6) Loosen the screw ⑪, then remove the thread take-up lever hinge pin ⑫.
- 7) Loosen the two screws ⑬, then remove the thread take-up lever assembly ⑭. (The washer ⑮ will come off.)
- 8) Remove the oil caps ⑯ and ⑰. (These caps must be removed to attach the wick.)



# ASSEMBLY

## 1 Needle bar mechanism

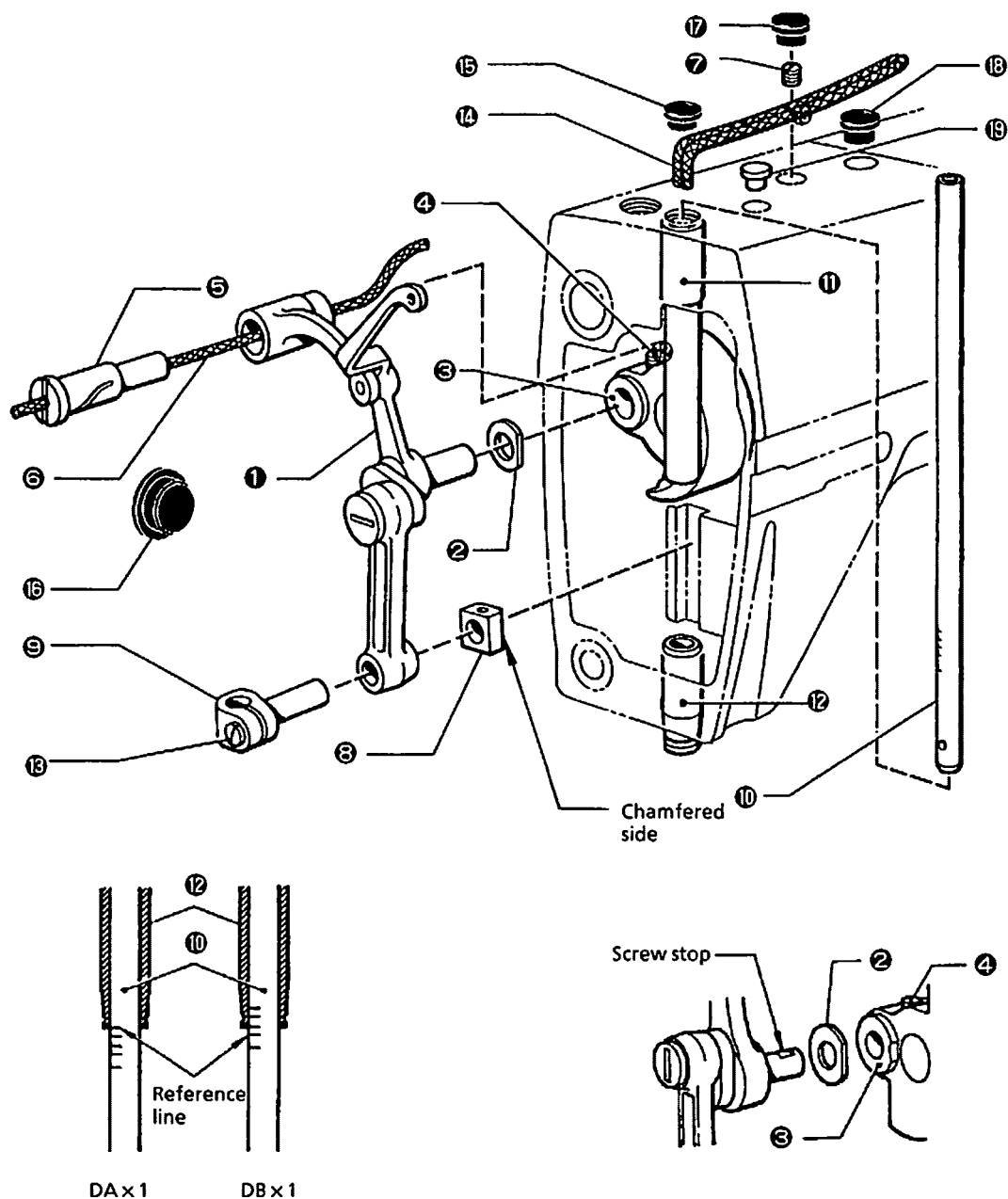

- 1) Secure the thread take-up lever assembly ① and the washer ② to the thread take-up crank ③ with the screw ④.  
NOTE: See the figure above for the correct position of the thread take-up crank screw stop.
- 2) Pass the wick ⑥ through the thread take-up lever hinge pin ⑤. (See page 24.)
- 3) While inserting the thread take-up lever hinge pin ⑤ into the thread take-up body, put all of them into the arm. Then secure them with the screw ⑦.
- 4) Slide the slide block ⑧ into the channel, then slide the needle bar guide clamp ⑨ into the thread take-up lever and the slide block ⑧.  
(Be sure the chamfered side of the slide block ⑧ is facing the inside.)
- 5) Pass the needle bar ⑩ from the top of the needle bar bushing (upper) ⑪ through the needle bar clamp ⑨.
- 6) Turn the machine pulley to lower the needle bar to its down position.
- 7) Align the needle bar ⑩ reference line with the bottom edge of the needle bar bushing (lower) ⑫, then tighten the screw ⑬. (The reference line to be aligned varies with the needle size.)
- 8) Pass the wick ⑭ from the arm top. (See page 24.)
- 9) Set the oil caps ⑮, ⑯, ⑰, ⑱, and ⑲ in place.

## 2 Feed mechanism

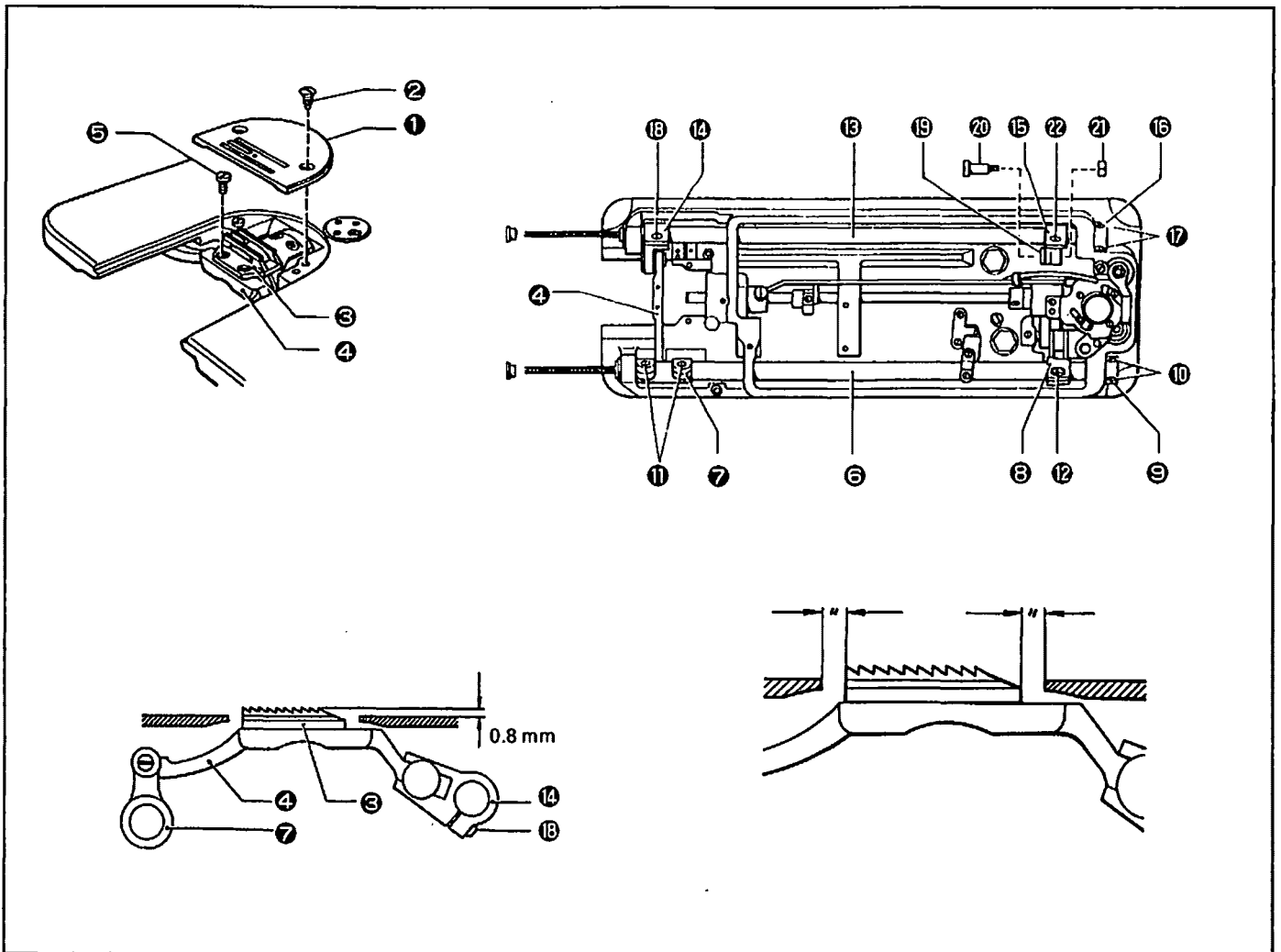

- 1) Secure the needle plate ① with the two screws ②.
- 2) Tilt the machine head until it stops.
- 3) Secure the feed dog ③ to the feed bracket assembly ④ with the two screws ⑤.
- 4) Insert the feed rock shaft ⑥ into the horizontal feed bracket arm ⑦ and the feed rock shaft arm ⑧.  
Then secure the feed rock shaft ⑥ with the set collar ⑨ and the two screws ⑩ so that it moves easily, but is not loose.
- 5) Center the feed dog ③ in the needle plate ① grooves and tighten the two screws ⑪ of the horizontal feed bracket arm ⑦.
- 6) Tighten the two screws ⑫ so that the feed rock shaft arm ⑧ moves easily.
- 7) Insert the feed lifting rock shaft ⑬ into the feed lifting crank assembly ⑭ and the feed lifting rock shaft crank ⑮.  
Then secure the feed lifting rock shaft ⑬ with the set collar ⑯ and the two screws ⑰ so that it moves easily, but is not loose.
- 8) Put the slide block of the feed bracket assembly ④ into the feed lifting crank assembly ⑭ and tighten the screw ⑱.
- 9) Secure the feed lifting rock shaft crank ⑮ and the vertical feed connecting rod ⑲ with the stud screw ⑳ and the nut ㉑.
- 10) Secure the feed lifting rock shaft crank ⑮ with the screw ㉒.
- 11) Minimize the feed amount and turn the machine pulley.
- 12) Adjust the feed dog ③ so that it extends 0.8 mm above the needle plate upper surface by loosening the screw ⑱.
- 13) Maximize the feed amount, and turn the machine pulley.
- 14) Adjust the feed dog ③ so that it is centered in the needle plate grooves by loosening the two screws ⑪.

NOTE: Make sure the pulley turns easily. Tighten the screws firmly.

When removing the feed rock shaft ⑥ and the feed lifting rock shaft ⑬, be sure to pass the wick into these shafts, and lubricate the horizontal feed bracket arm ⑦ and feed lifting crank ⑭.

## Passing a wick

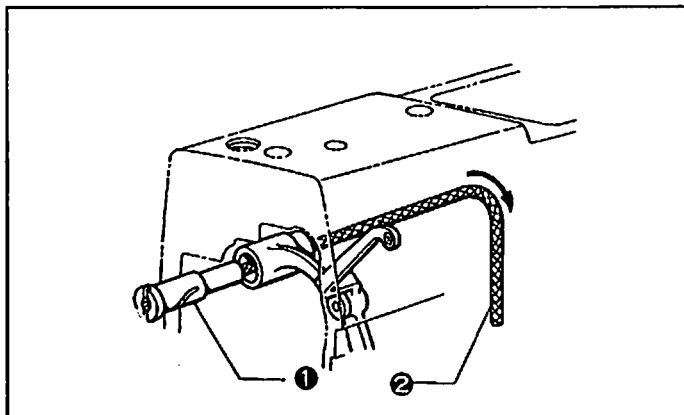

- 1) Pass the wick ② through the thread take-up lever hinge pin ①.
- 2) Pull the wick to the upper cover, then dangle the wick without touching any parts.

NOTE: The wick length: approx. 110 mm

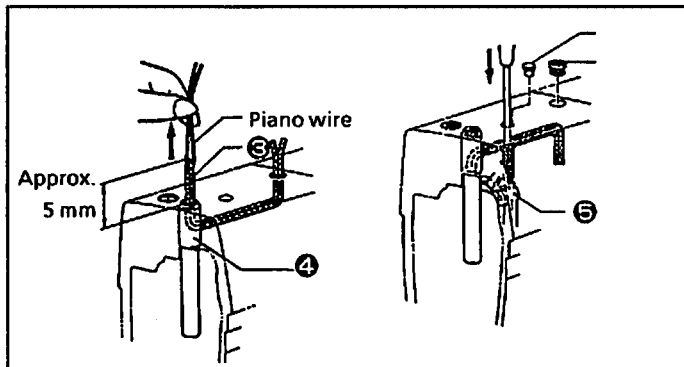

- 1) Pass the wick ③ from the arm top. Extend approximately 5 mm of the wick from the needle bar bushing ④ side.
- 2) Turn the machine pulley manually to raise the thread take-up to its highest position.
- 3) As shown in the figure on the left, push in the wick ③ until it contacts the top of the thread take-up body ⑤.

- 4) Push both ends of the wick ③ in the holes.

NOTE: The wick length: approx. 300 mm

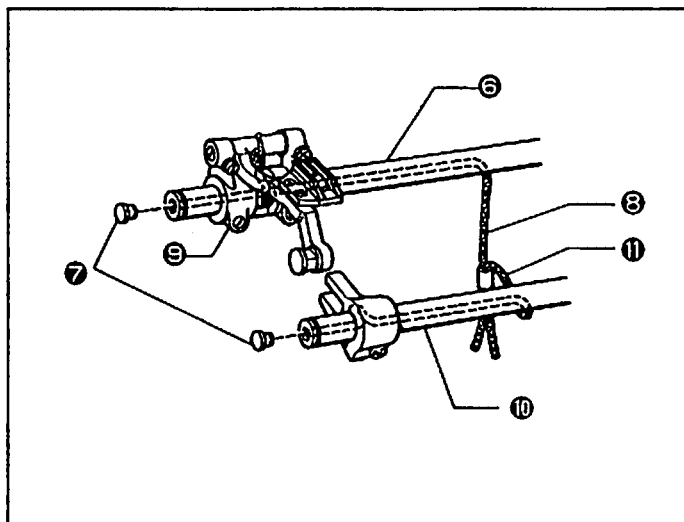

- 1) Remove the oil cap ⑦ from the feed rock shaft ⑥.
- 2) Pass the wick ⑧ into the feed rock shaft ⑥ until one end of the wick ⑧ reaches the far end of the feed rock shaft ⑥.
- 3) Attach the oil cap ⑦.

- 4) Attach the oil cap of the horizontal feed bracket arm ⑨ on the feed rock shaft ⑥.

- 5) Remove the oil cap ⑦ from the feed lifting rock shaft ⑩.

- 6) Pass the wick ⑪ into the feed lifting rock shaft ⑩ until one end of the wick ⑪ reaches the far end of the feed lifting rock shaft ⑩.

- 7) Attach the oil cap ⑦.

- 8) Pull out the wick ⑪ through the feed lifting rock shaft ⑩ to contact the slide block on the feed bracket assembly.

### 3 Thread trimmer

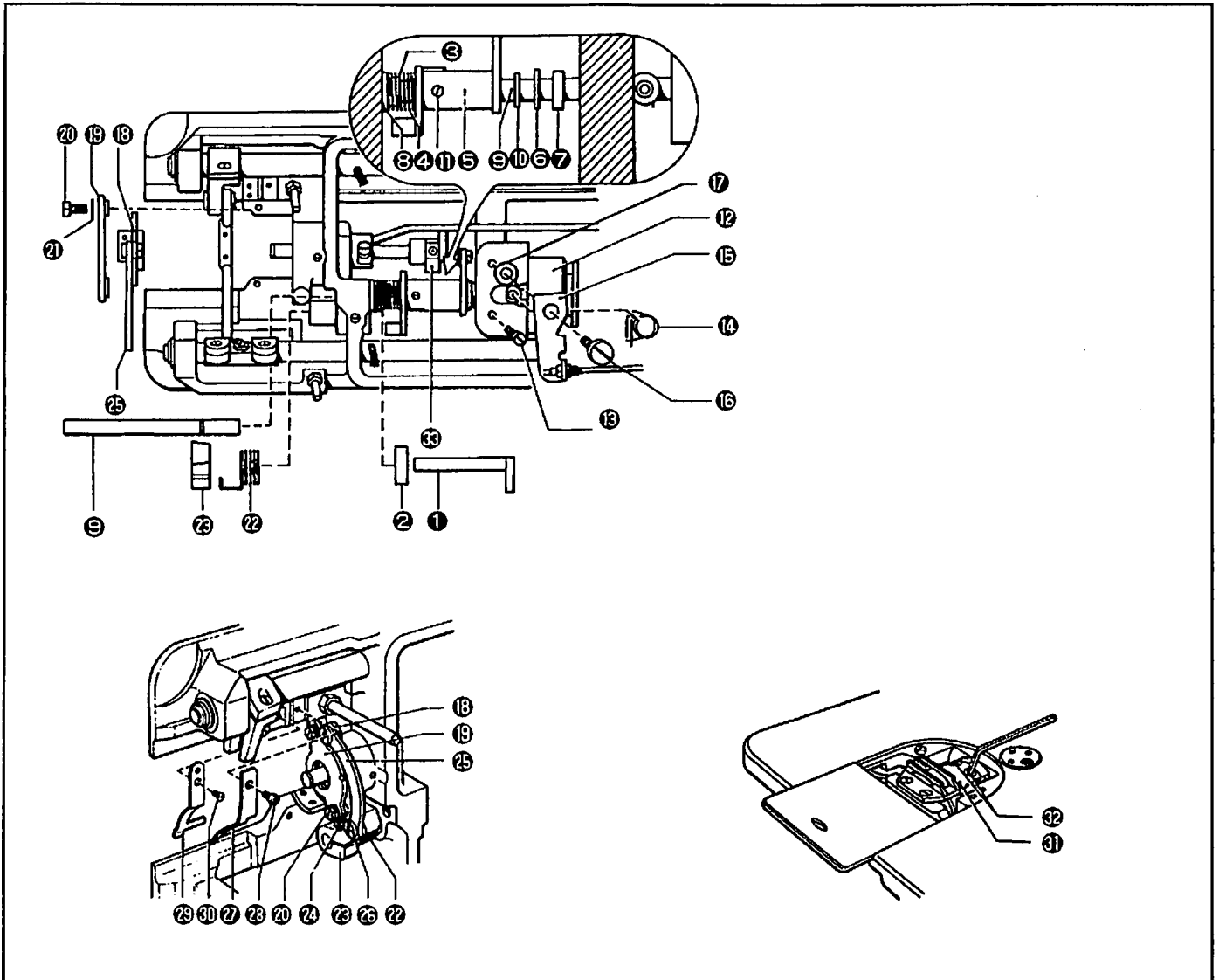

- 1) Attach the forked shaft ① to the collar ②, and attach them to the arm bed.
- 2) Attach the slide block ③ of the thread trimmer cam lever assembly ⑤ to the forked shaft ① branch. Set the collar ③, the thread trimmer cam lever spring ④, the thread trimmer cam lever assembly ⑤, the washer ⑥, and the cushion ⑦ in the arm bed. Then insert the thread trimmer cam lever stud ⑧ into all of them.
- 3) Place the stop ring ⑩ onto the thread trimmer cam lever stud ⑧.
- 4) Tighten the screw ⑪.
- 5) Attach the thread trimmer solenoid ⑫ to the arm bed with the screw ⑬.
- 6) Attach the tension releasing spring ⑭ and the tension releasing lever ⑮ with the screw ⑯ and the washer ⑰. (See page 35 when adjusting the tension releasing lever.)
- 7) Set the movable knife holder ⑱ in the arm bed. Secure the knife holder presser ⑲ with the bolt ⑳ and the washer ㉑.
- 8) Place the thread trimmer lever spring ㉒ and the thread trimmer lever ㉓ on the forked shaft ①, and tighten the screw ㉔.
- 9) Attach the thread trimmer rod ㉕ to the thread trimmer lever ㉓ with the stud screw ㉖.
- 10) Secure the lower thread finger ㉗ in the arm bed with the screw ㉘.
- 11) Secure the fixed knife ㉙ in the arm bed with the screw ㉚.
- 12) Attach the movable knife ㉛ to the movable knife holder ⑱ with the screw ㉜.
- 13) Hook the thread trimmer lever spring ㉒ on the thread trimmer lever ㉓.
- 14) Check the thread trimmer clutch ㉝ position.

NOTE: Slide the lower thread finger ㉗ to the movable knife ㉛ to give the proper gap between the lower thread finger ㉗ and the rotary hook.  
In model DB2-B7740, attach the relection sensor holder when attaching the lower thread finger ㉗.

## Adjusting the thread trimmer timing

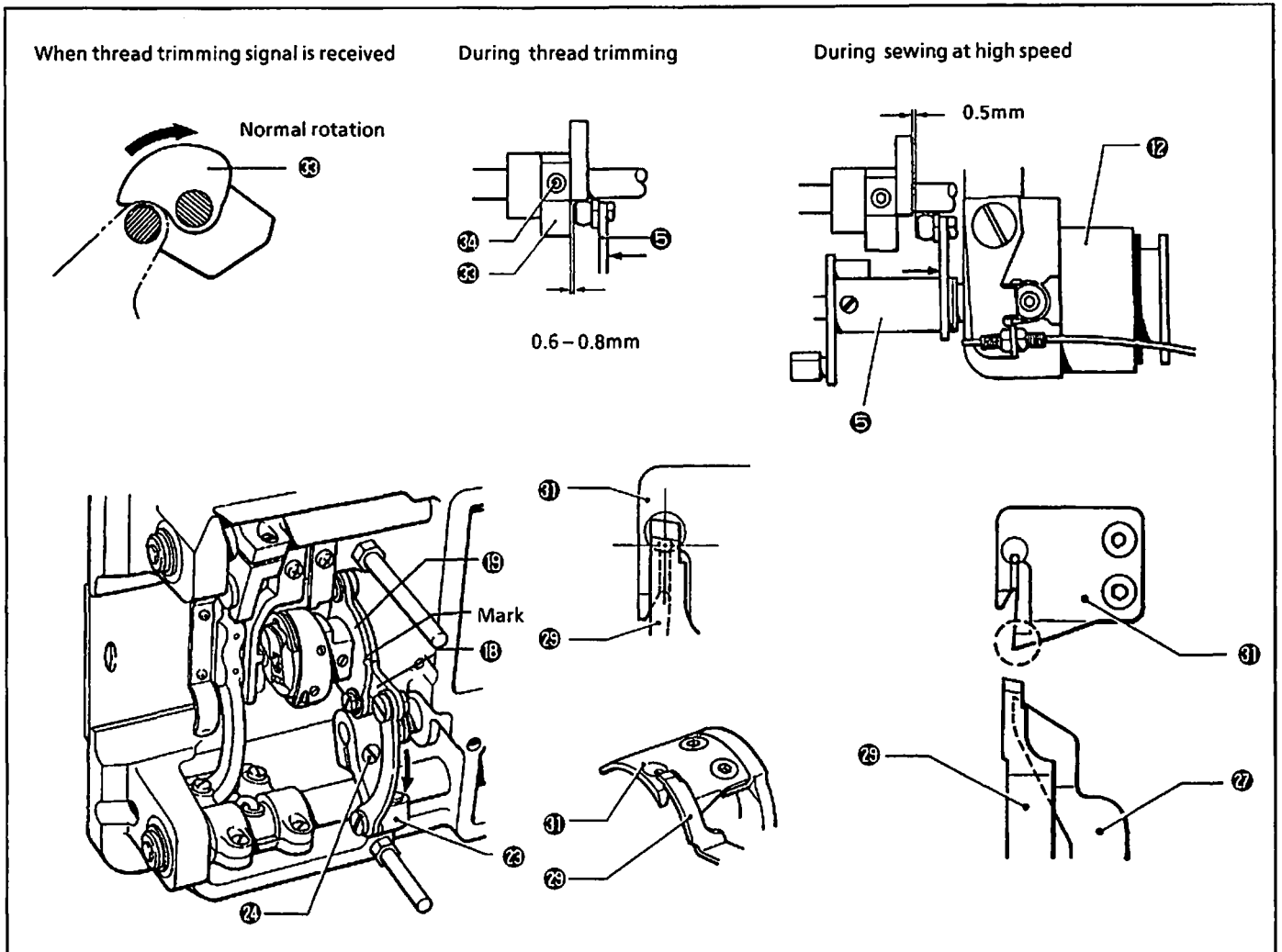

### 1. Adjusting the thread trimmer clutch position

Turn the machine pulley until the needle bar is raised 5 mm above its lowest position. When pressing the thread trimmer solenoid 12 manually, loosen the screw 24 and adjust the thread trimmer clutch 23 so that its indent contacts the roller bearing, and so that the space between the end faces of the thread trimmer clutch 23 and the roller bearing is 0.6-0.8 mm.

### 2. Adjusting the movable knife and fixed knife positions

The fixed knife 26 tip and the movable knife 21 must overlap for 1 mm when the roller bearing of the thread trimmer cam lever 5 is lifted to the top of the thread trimmer clutch 23. (The notch marks of the movable knife holder 18 and the knife holder presser assembly 19 will be aligned.)

If they do not overlap, shift the thread trimmer lever 25 so that the knives (26 and 21) overlap when the roller bearing is lifted to the top of the thread trimmer clutch 23. Then tighten the screw 24.

NOTE: The lower thread finger 27 should be below the movable knife.

## 4 Rotary hook mechanism

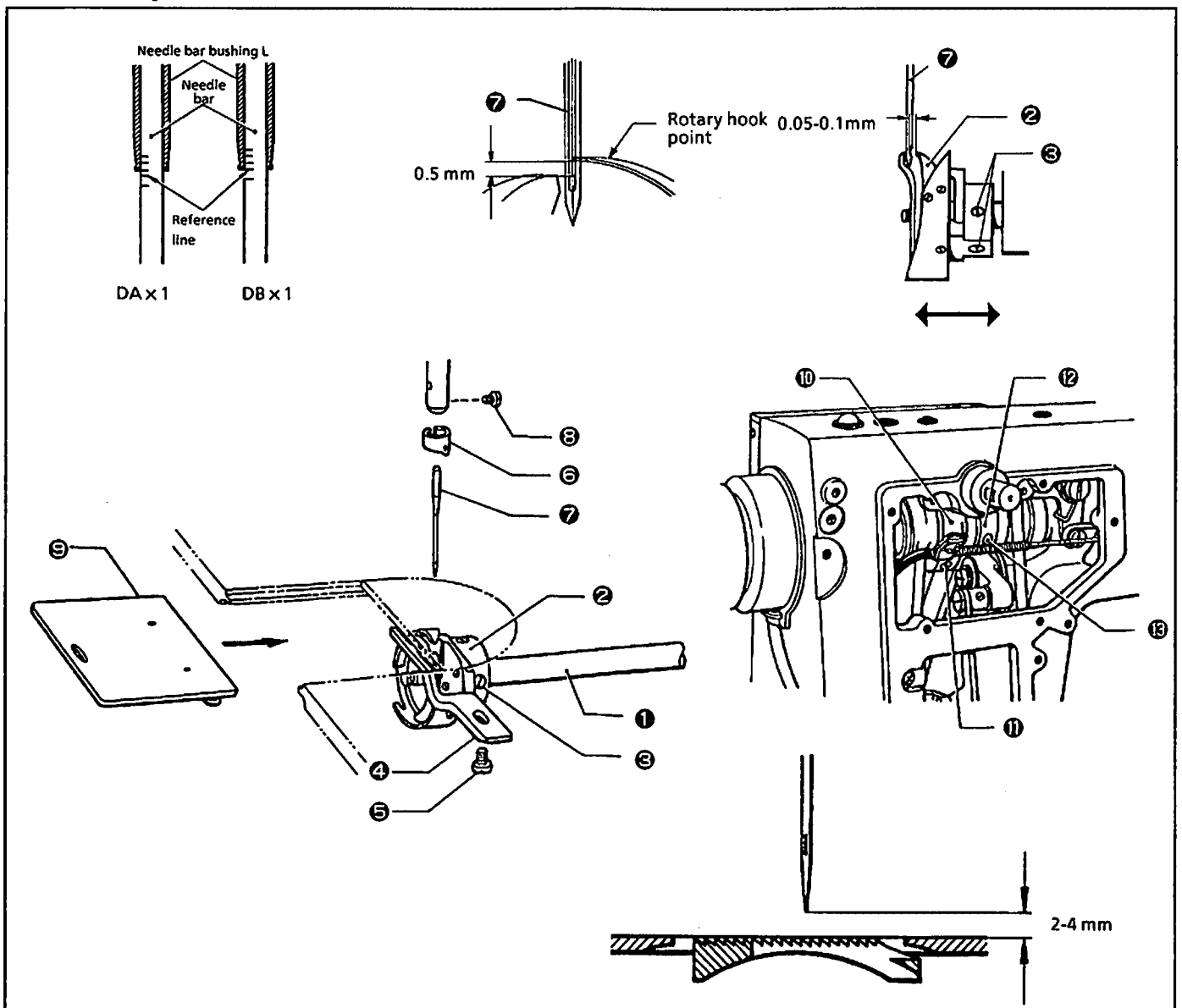

- 1) Place the rotary hook ② on the lower shaft ① and tighten the screw ⑤.
  - 2) Secure the bobbin case holder position bracket ④ with the screw ⑤.
  - 3) Place the needle bar thread guide ⑥ and secure the needle ⑦ with the screw ③.
  - 4) Adjust the timing between the needle ⑦ and the rotary hook ② as follows:  
While raising the needle bar 1.8 mm above its lowest position by turning the machine pulley, align the rotary hook point with the needle center (see the reference line in the figure above). At this time, the gap between the rotary hook point and the needle hole top is 0.5 mm. Adjust the gap between the needle ⑦ and the rotary hook point to 0.05-0.1 mm.
  - 5) Attach the needle plate.
  - 6) Attach the slide plate ⑧.
  - 7) Adjust the feed timing.
  - 8) Set the feed amount to 0.
  - 9) Turn the pulley towards the machine front. When the feed dog descends and is aligned with the needle plate's upper surface, the needle tip should be 2-4 mm above the needle plate's upper surface.  
To adjust the timing, turn the level feed eccentric wheel ⑩ and the feed lifting eccentric wheel ⑫ by loosening the screw ⑪ of the wheel ⑩ and the screw ⑬ of the wheel ⑫.
- NOTE: In model DB2-B7740, attach the needle plate after putting the reflector through the sensor hole. Then position the reflector.  
Make sure the gap between the bobbin case holder position bracket ④ and the rotary hook ② is sufficient to allow the thread to pass easily.  
Make sure the rotary hook ② does not strike the lower thread finger.

## 5 Presser foot mechanism

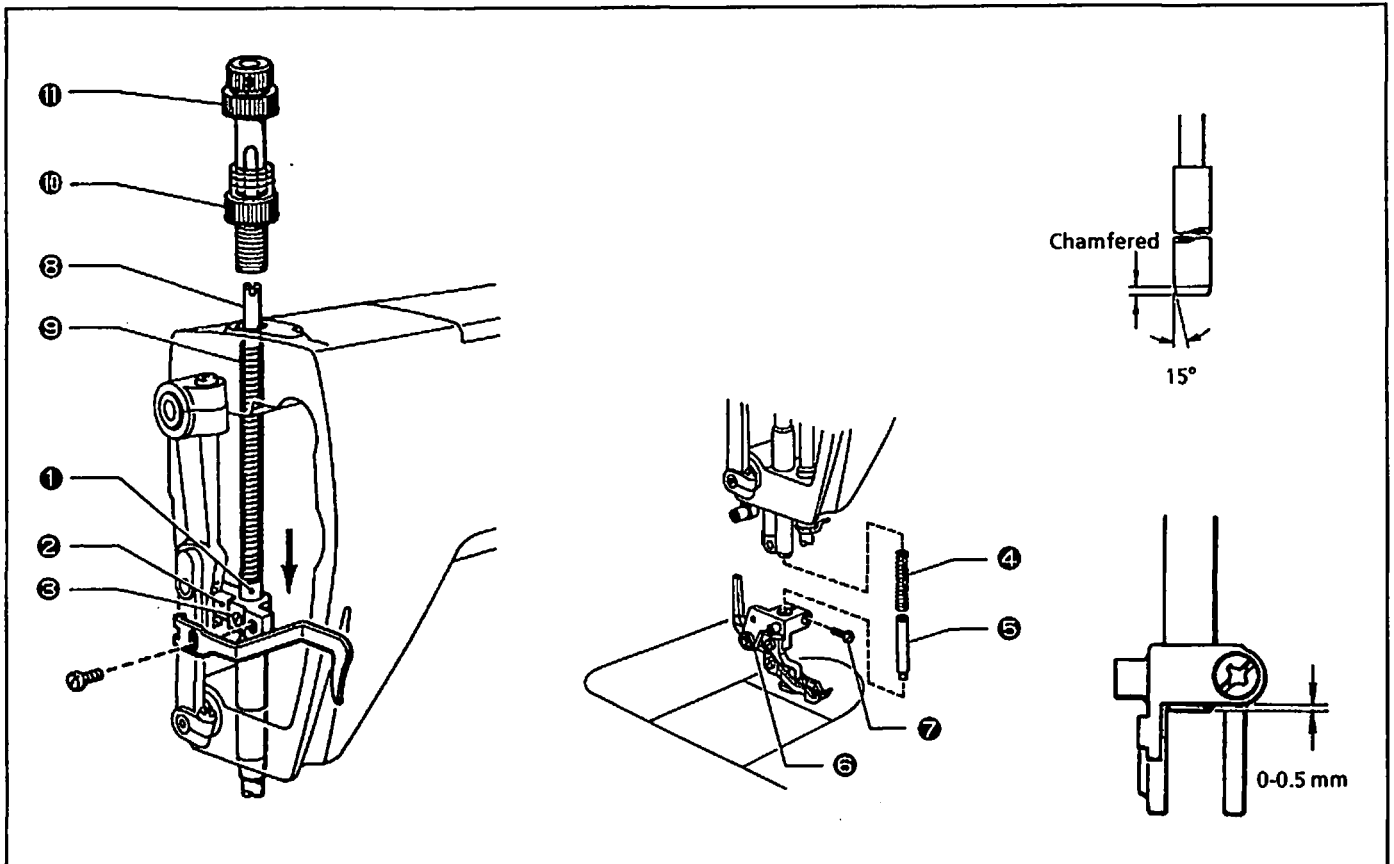

- 1) Raise the machine head.
  - 2) Insert the presser bar ① from the top of the arm.
  - 3) Put the presser bar clamp ② on the arm channel, insert the presser bar ① into the presser bar clamp ②, and tighten the screw ③ temporarily.
  - 4) Put the spring ④ and the pin ⑤ into the hole of the presser bar, then attach the upper feed bracket assembly ⑥ to the presser bar ① using the screw ⑦.
- NOTE: Insert the presser bar ① into the upper feed bracket ⑥ and tighten the screw ⑦ so that the tip of the presser bar ① extends 0-0.5mm from the bottom of the upper feed bracket.  
Check that 15° chamfered side of the presser bar ① is below.
- 5) Attach the adjusting screw ⑧ and the presser spring ⑨ to the machine head, using the presser regulating screw ⑩.
  - 6) Check that the needle is in the center of the presser foot groove.
  - 7) Lift the presser foot with the presser bar lifter, then adjust the amount that the presser foot rises to 6mm, and tighten the screw ⑧.
  - 8) Tighten the presser regulating dial ⑪.

## 6 Upper feed mechanism

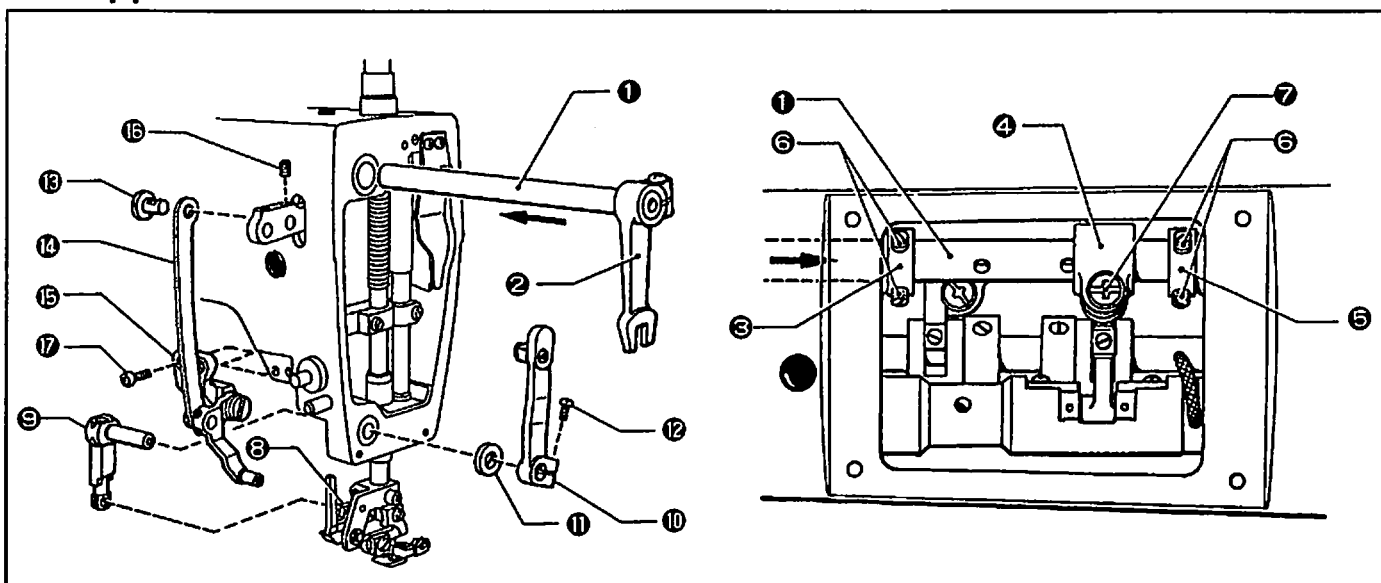

- 1) Attach the upper feed rock shaft ① and the upper feed rock arm (upper) ② to the machine head. Then attach the upper feed rock shaft ① to the collar ⑤, the upper feed rock shaft ④, and the collar ⑤ in that order with the screws ⑥.
- 2) Tighten the screw ⑦ firmly.
- 3) Attach the upper feed arm assembly ③ to the upper feed bracket assembly ③ pin. Then attach them to the arm.
- 4) Insert the upper feed rock arm (lower) ⑩ into the branch of the upper feed rock arm (upper) ②. Place the washer ⑪ on the upper feed rock arm (lower) ⑩. Then attach them to the upper feed arm assembly ③.
- 5) Tighten the screw ⑫ firmly.
- 6) Attach the connecting lever stud ⑯, the upper feed connecting lever ⑭, and the crank assembly ⑮ with the screw ⑬ and the two screws ⑰.

NOTE: After assembling the upper feed mechanism, see page 36 " 6 Adjusting the timing of the upper feed vertical movement," and page 35 " 5 Adjusting the timing of the upper feed horizontal movement."

Tighten the screws firmly.



## 7 Machine covers

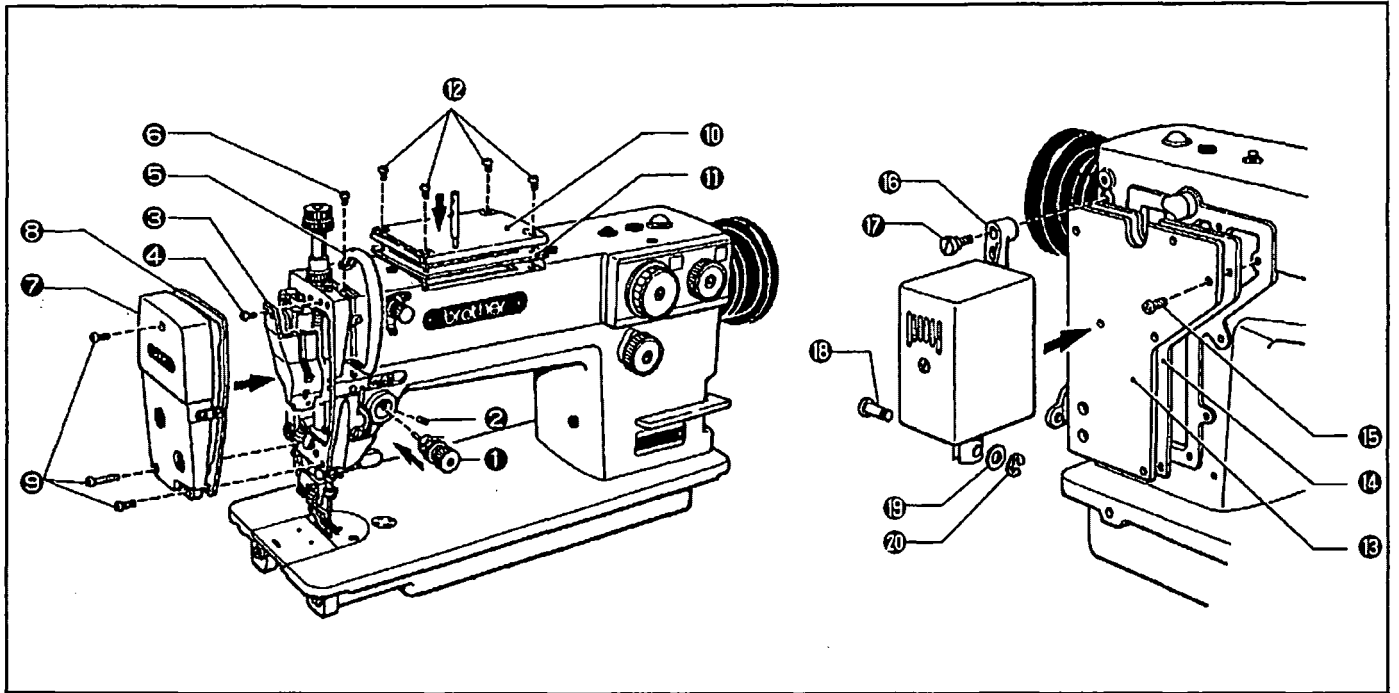

- 1) Secure the upper tension regulator bracket ① with the screw ②. Align the screw ② with the screw stop of the upper tension regulator bracket ①.
- 2) Secure the oil stopper plate ③ with the two screws ④.
- 3) Secure the thread take-up cover ⑤ with the screw ⑥.
- 4) Secure the face plate ⑦ and the face plate packing ⑧ with the three screws ⑨.
- 5) Secure the upper cover ⑩ and the upper cover packing ⑪ with the four screws ⑫.
- 6) Secure the rear cover ⑬ and the rear cover packing ⑭ with the six screws ⑮.

For a sewing machine with an automatic thread trimmer:

Secure the solenoid bracket ⑯ with the three screws ⑰, the connecting pin ⑱, stop ring E ⑲, and the washer ⑳.

# ADJUSTMENT

## 1 Adjusting the timing between needle and rotary hook

Proper timing between the needle and the rotary hook is required for the needle to rise from its down position, then to form a loop which is caught by the rotary hook point.

### 1. Needle bar rise

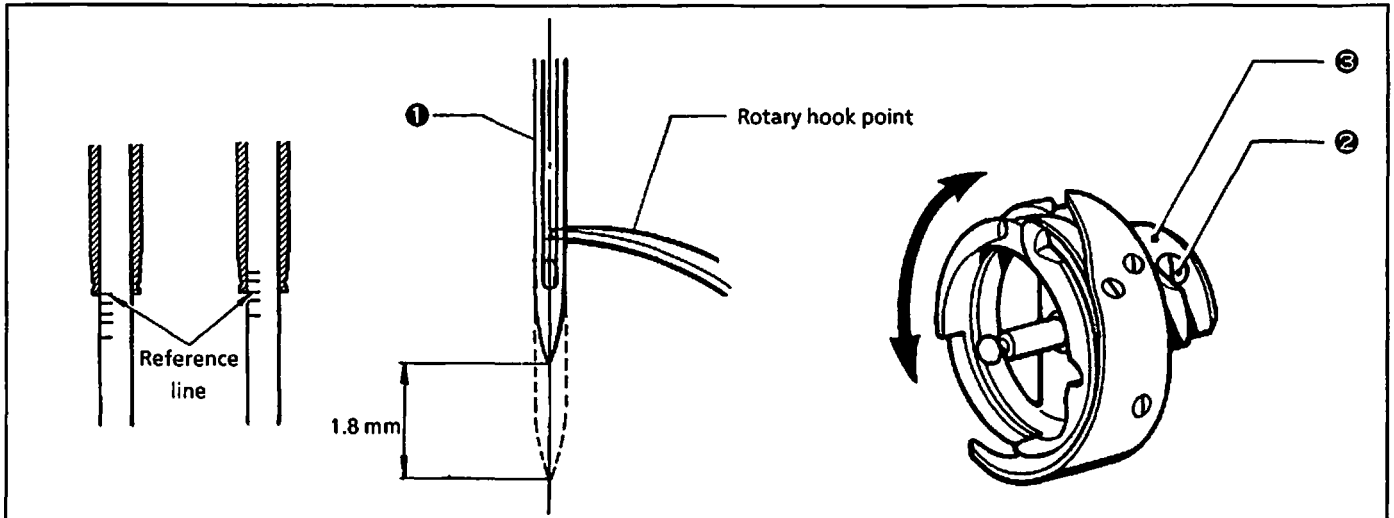

Rotate the machine pulley until the needle ① is raised 1.8 mm above its down position. Loosen the screw ②, then turn the rotary hook ③ to adjust it so that the rotary hook point is aligned with the needle ① center.

### 2. Needle bar height

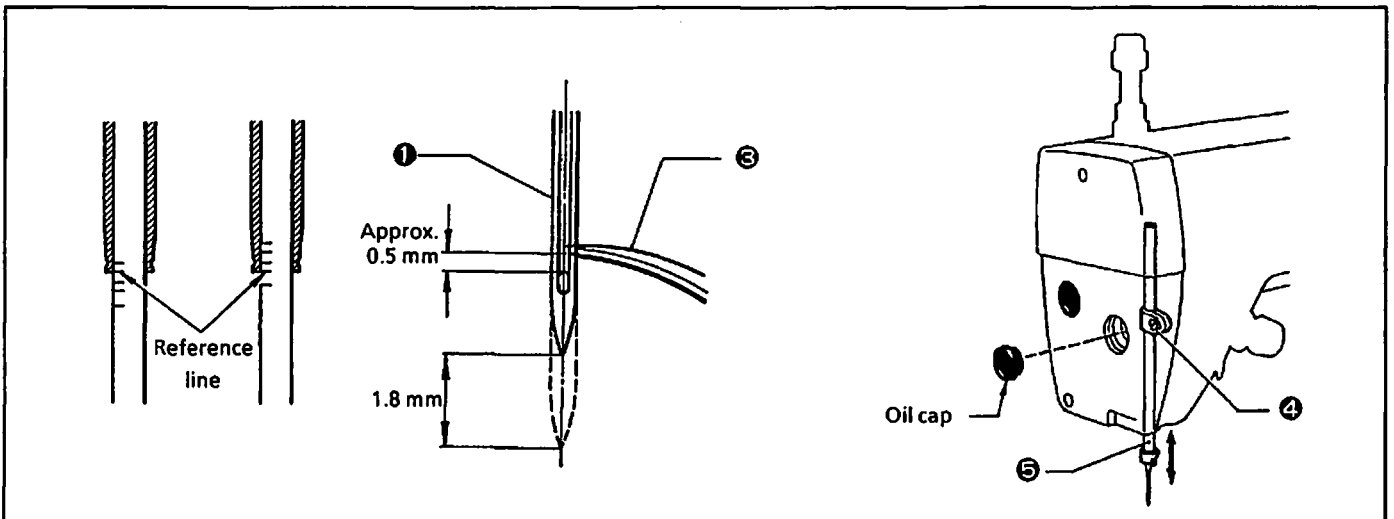

After rotating the machine pulley until the rotary hook point is aligned with the needle ① center, remove the oil cap, loosen the screw ④, then adjust the needle bar ⑤ height so that the gap between the rotary hook point ③ and the needle ① hole top edge is approximately 0.5 mm.

**3. The gap between the needle and the rotary hook point**  
Loosen the screw ②, then adjust the gap to 0.05-0.1 mm by moving the rotary hook ③ back and forth.

**4. The gap between the rotary hook and the bobbin case holder position bracket**  
Check that the gap allows the thread to pass smoothly. With thin and medium materials the gap should be 0.4-0.7 mm.

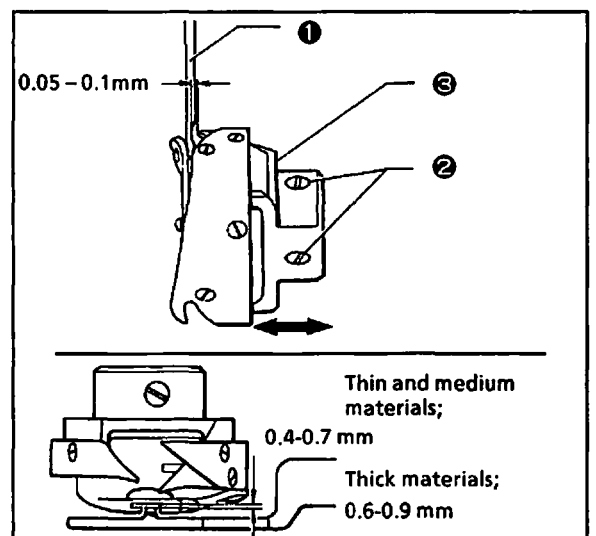

## 2 Adjusting the timing between needle and feed

### 1. Adjusting the feed dog height and angle

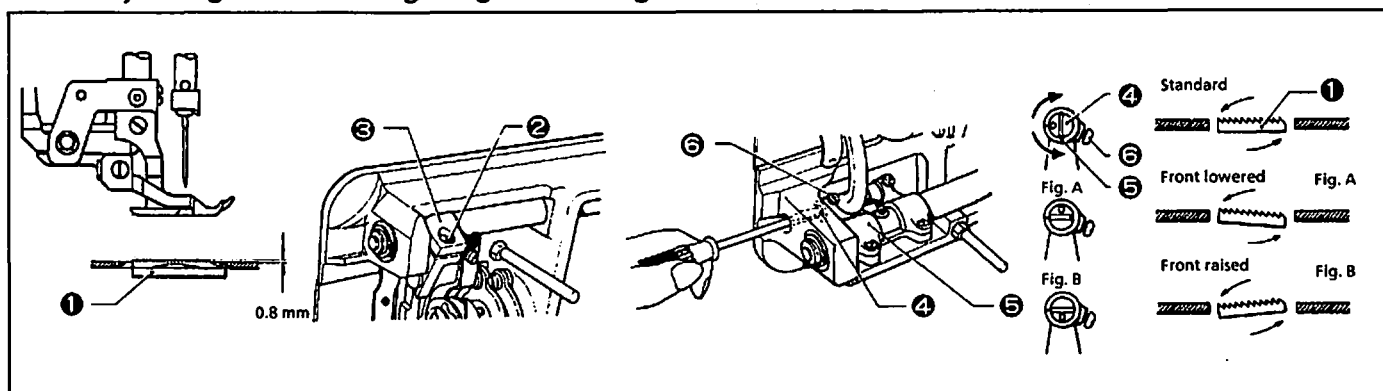

#### Feed dog height

- 1) When the feed dog ① is fully raised, the standard height of the feed dog is 0.8 mm.
- 2) To adjust the height, when the feed dog ① is fully raised, loosen the screw ②, rotate the feed lifting crank ③ and move the feed bracket up and down.

#### Feed dog angle

- 1) When the feed dog ① is fully raised, its angle is properly adjusted when the circle on the feed bracket shaft ④ aligns with the index on the feed rock shaft arm ⑤.  
To prevent puckering, lower the feed dog ① front. (Fig. A)  
To prevent materials from slipping, raise the feed dog ① front. (Fig. B)
- 2) To adjust the angle, loosen the screw ⑥ and then rotate the feed bracket shaft ④ within 90° in the directions indicated by the arrows.

### 2. Adjusting the feed timing

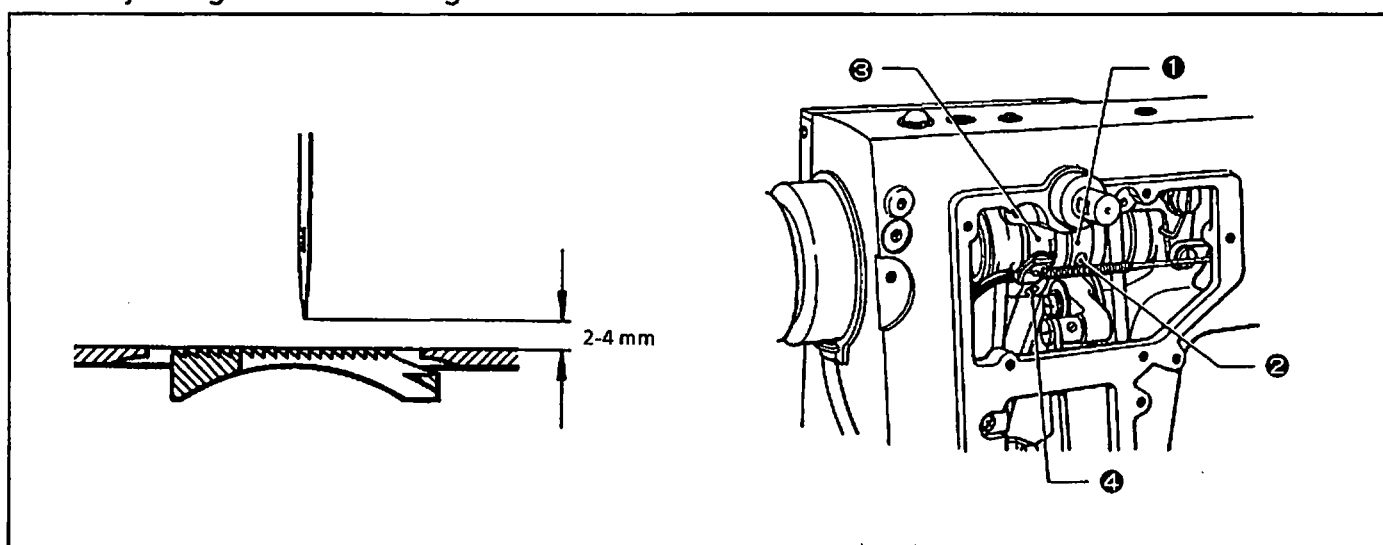

- 1) Turn the machine pulley toward the machine front until the feed dog descends and the tips of the feed dog align with the needle plate's upper surface. At this time, check that the needle tip is 2-4 mm above the needle plate's upper surface.
- 2) To adjust the timing, loosen the screw ② of the feed lifting eccentric wheel ① and the screw ④ of the level feed eccentric wheel ③.  
If the feed dog descends below the needle plate too soon, turn the feed lifting eccentric wheel ① and the level feed eccentric wheel ③ opposite to its normal rotation. If the feed dog is delayed, turn the wheels ① and ③ slightly forward.
- 3) After adjusting the timing, firmly tighten the screws ② and ④.

### 3 Adjusting the forward and backward stitch lengths

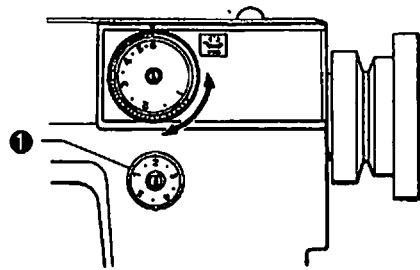

[DB2-B773-003]

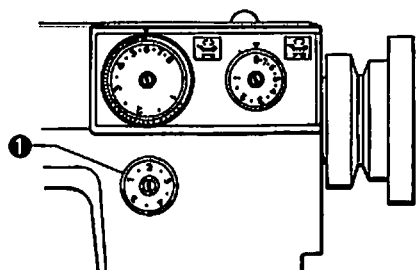
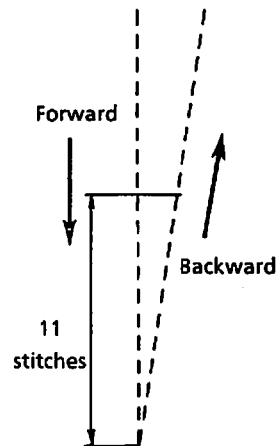

[DB2-B773-006]

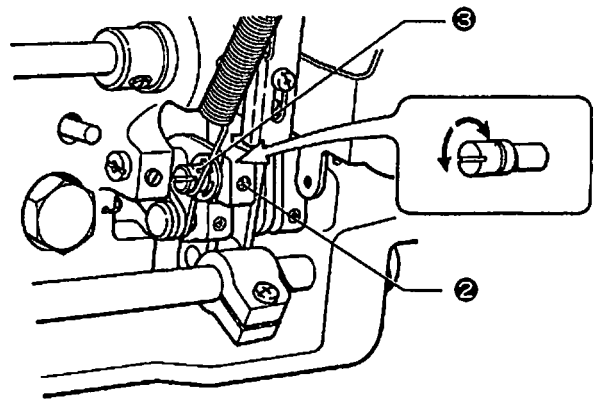

- 1) Set the length control assembly ❶ to mark 3.
  - 2) Sew 11 stitches forward and backward at the inching speed (215 spm).
  - 3) Adjust as follows when the forward and backward feed stitch lengths are different.
    - 1) Tilt the machine head until it stops.
    - 2) Loosen the screw ❷.
    - 3) When the forward stitch length is greater than the backward one, rotate the pin ❸ clockwise. When the forward stitch length is less than the backward one, rotate the pin ❸ counterclockwise.
- NOTE: If the pin ❸ has been rotated 180°, these adjustments should be reversed.  
After adjusting the stitch lengths, firmly tighten the screw ❷.  
Rotation of the length control assembly ❶ (changing the feed amount) changes the forward and backward stitch lengths.

#### 4 Zeroing feed regulator and adjusting reverse lever

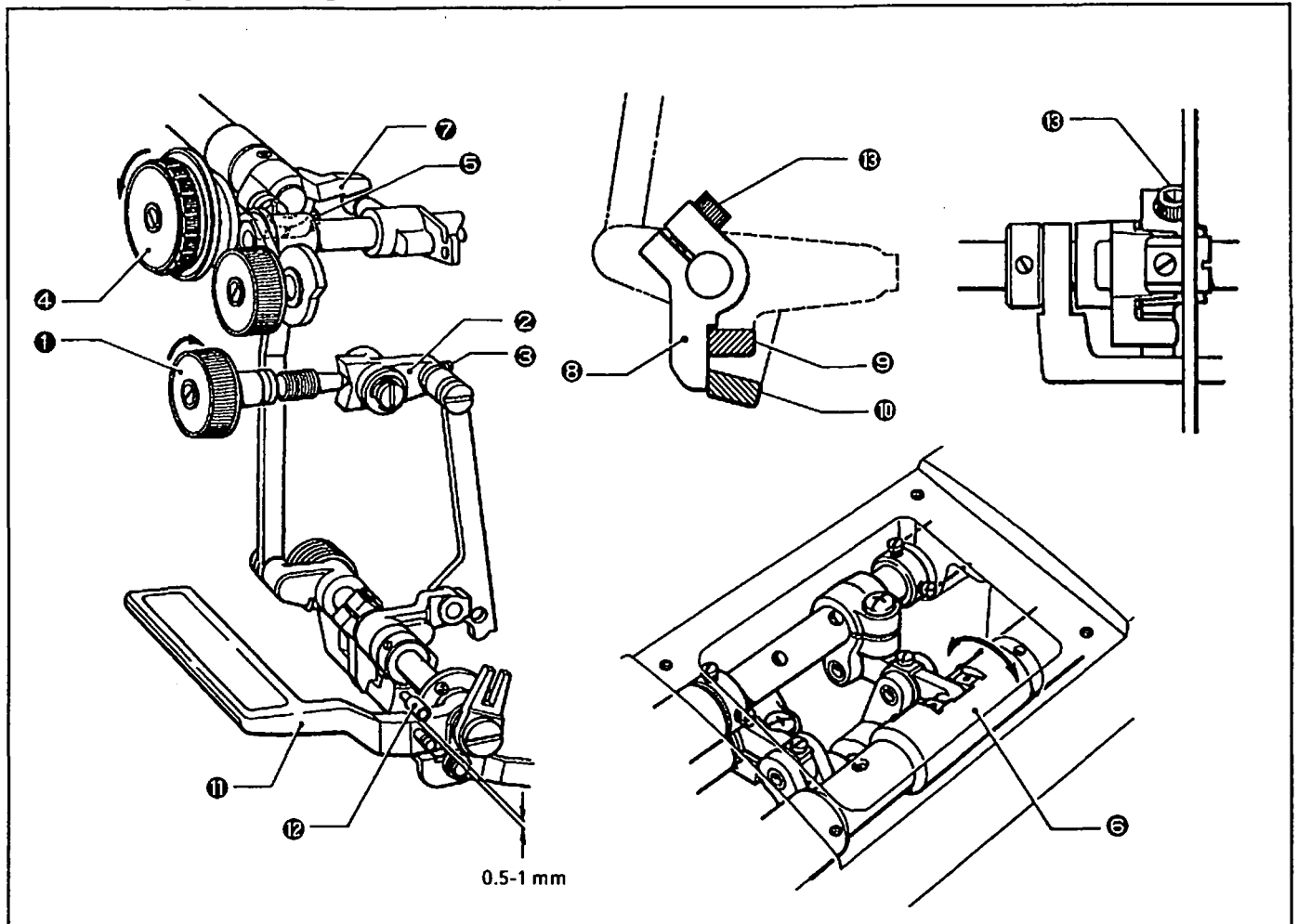

- 1) Screw in the length control assembly ① in the direction of the arrow so that the feed regulator ② is secured.  
NOTE: If the feed regulator ② is still not secured, loosen the screw ③, unscrew the length control assembly ①, tighten the screw ③, and secure the feed regulator ② by turning the feed regulating dial ①.
- 2) Turn the upper feed regulating plate assembly ④ in the direction of the arrow to the maximum value.
- 3) By rotating the pulley, check that the maximum amount of the upper feed dog horizontal movement is within the set maximum values (5.5 to 6.0 mm for subclass -003, 7.5 to 8.0 mm for subclass -006). When it exceeds or is short of the maximum value, loosen the screw ⑤ and adjust the maximum amount of movement by rotating the feed regulator shaft ⑥.
- 4) After completing the above adjustment, tighten the screw ⑤.  
Be sure not to move the upper feed regulator assembly ⑦.
- 5) Tighten the bolt ⑧, so that the gap between the reverse lever ⑪ and the stopper pin ⑫ is 0.5 to 1.0mm when the feed regulating lever ③ is touching the feed regulator levers (lower) ⑨ and (upper) ⑩. Tighten the bolt ⑧ to secure the feed regulator levers (lower) ⑨ and (upper) ⑩.  
NOTE: After depressing the reverse lever, check that it returns easily to its former position.

## 5 Adjusting the timing of upper feed horizontal movement

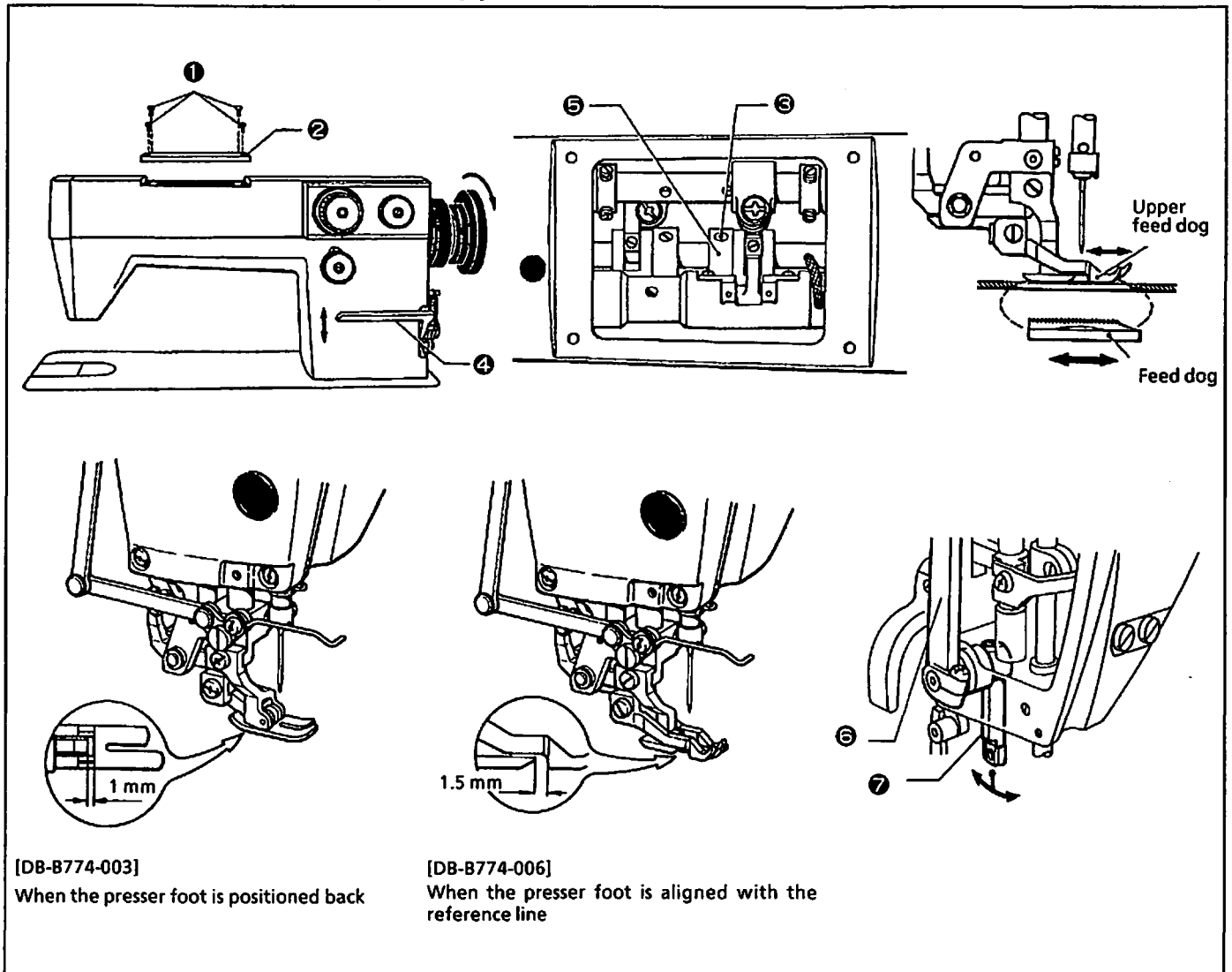

- 1) Maximize the upper feed amount by turning the upper feed regulating plate assembly.
- 2) Maximize the feed amount by turning the length control assembly.
- 3) Remove the screw ① and the upper cover ②.
- 4) Loosen the screws ③.
- 5) While slowly rotating the machine pulley in its normal rotating direction, press down and pull up the reverse lever ④, and stop moving it where the feed dog stops.  
NOTE: There are two positions for the adjustment described above; above and below the needle plate.  
For this adjustment, use the above-the-plate position only.
- 6) While slowly rotating the eccentric wheel ⑤, push down and pull up the reverse lever ④, stop moving it where the upper feed dog stops, and tighten the screw ③.

### Adjusting the clearance between the upper feed dog and the presser foot

- 1) Remove the face plate.
- 2) Maximize the upper feed amount by turning the upper feed regulating plate assembly.
- 3) Slowly rotate the machine pulley.
- 4) The clearance between the upper feed dog and the presser foot when the two come nearest should be about 1mm for the pucker type, and 1.5mm for the gather type.
- 5) Loosen the screw ③, and adjust the clearance by moving the upper feed arm ⑦ forward and backward.

## 6 Adjusting the timing of the upper feed vertical movement

When the tips of the feed dog are raised from its lowest point to the needle plate's upper surface, the tips of the upper feed dog should touch the needle plate's upper surface.

Make the following adjustment.

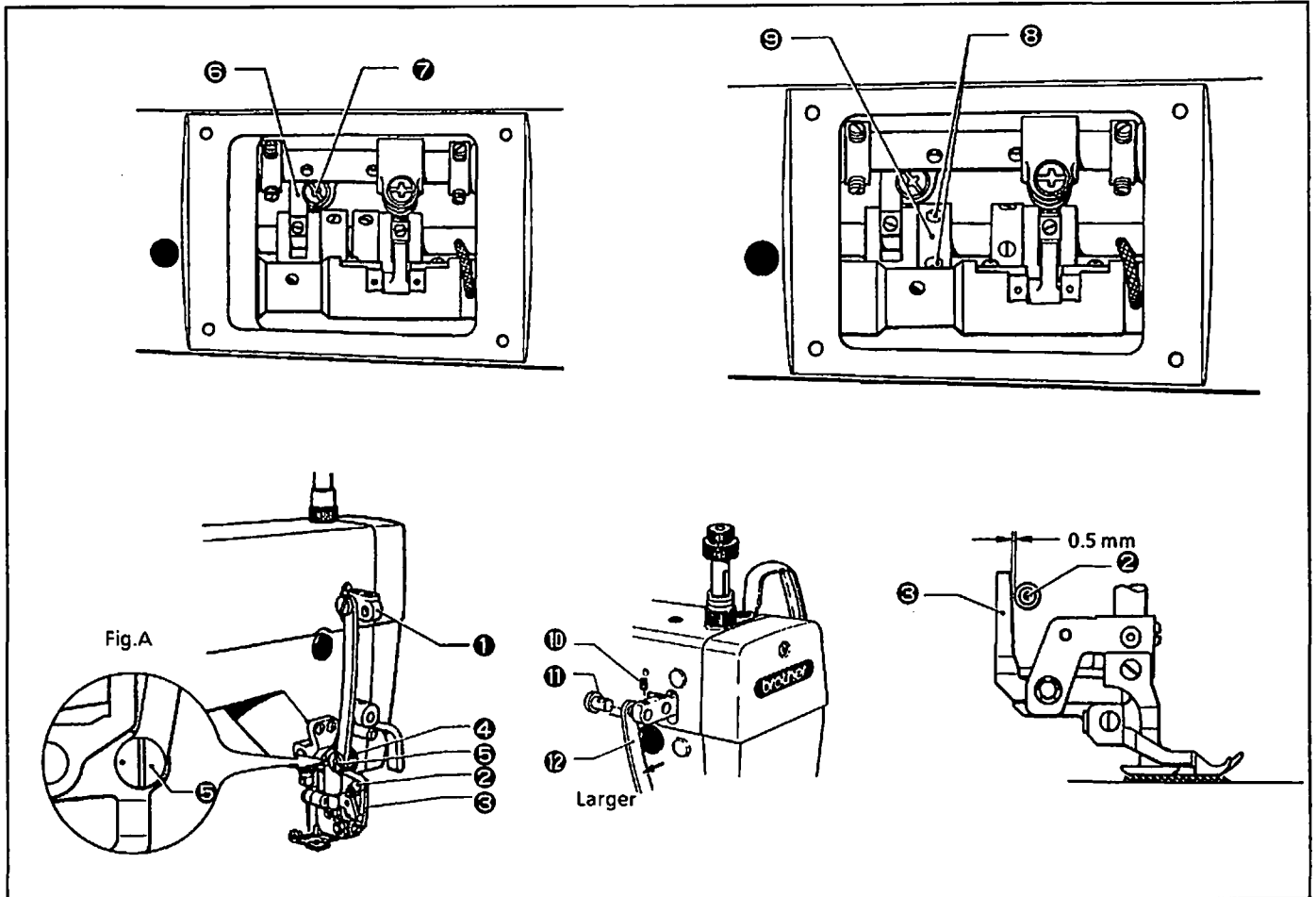

- 1) Maximize the upper feed amount by turning the upper feed regulating plate assembly.
- 2) Rotate the machine pulley. When the upper feed lifting rock arm ① is at its lowest position, the gap between the upper feed lifting rock crank ② and the upper feed bracket assembly ③ should be 0.5 mm. Adjust the gap by loosening the screw ④ and turning the pin ⑤.  
If the gap cannot be adjusted with the pin ⑤, turn the pin ⑤ back and tighten it with the screw ④ as shown in Fig. A. Then remove the upper cover, loosen the screw ⑦ of the upper feed lifting rock lever ⑥, and adjust the gap by moving the upper feed lifting rock arm ① up and down. Tighten the screw ⑦ firmly.
- 3) From its upper position, lower the needle, by rotating the pulley, until the needle tip is just above the needle plate's upper surface.
- 4) Loosen the screw ⑧, rotate the eccentric wheel ⑨ in the normal rotation direction of the machine, then rotate it in the opposite direction. Attach the roller bearing of the upper feed lifting rock crank ② to the upper feed bracket assembly ③, and tighten the screw ⑧ of the eccentric wheel ⑨.

**NOTE:** When the upper feed dog moves early, loosen the screw ⑧ and rotate the eccentric wheel ⑨ in the direction opposite of the machine rotation. When it moves late, loosen the screw ⑧ and rotate the eccentric wheel in the direction that the machine rotates.

If you need a larger upper feed dog movement for sewing things such as thick material, remove the screw ⑩ of the upper feed lifting rock arm ①, place the connecting stud ⑪ and the upper feed connecting lever ⑫ into the outer hole, and tighten it with the screw ⑩. Then readjust the up and down timing using the eccentric pin ⑤ of the upper feed lifting rock crank assembly ②.

## 7 Adjusting presser foot

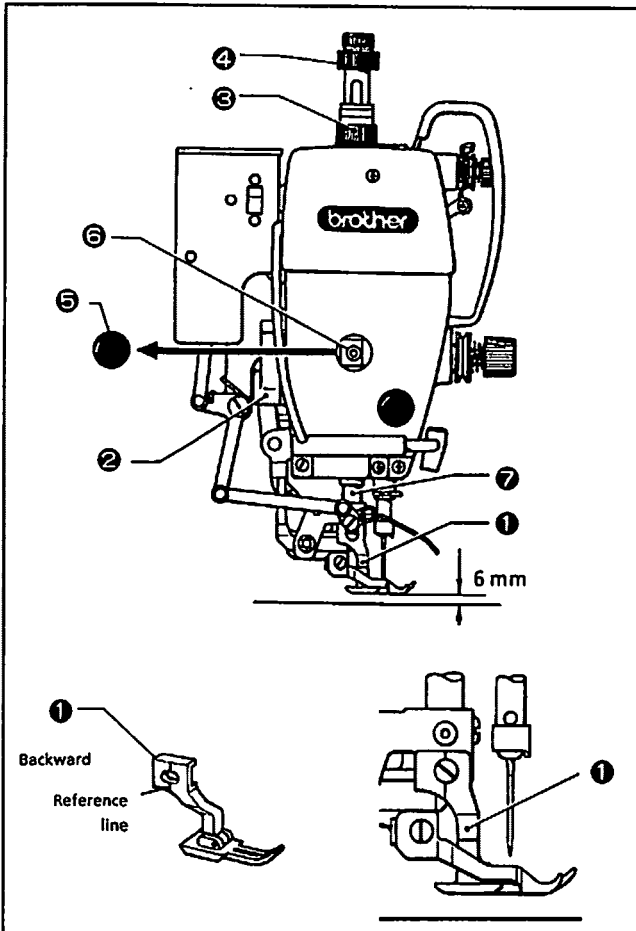

### Adjusting the clearance of the presser foot

- 1) The standard amount that the presser foot ① rises, when being raised by pulling up the presser bar lift ②, is 6mm.
- 2) Loosen the nut ⑤ and the presser regulating screw assembly ④.
- 3) Raise the presser foot ① by pulling up the presser bar lift ②.
- 4) Insert a 6 mm gauge under the presser.
- 5) Remove the oil cap ⑤, and loosen the screw ⑥. Adjust the clearance by moving the presser bar ⑦.

### Adjusting the forward and backward position of the presser foot

If you want to make the needle thread tension stronger when sewing with a longer stitch length, place the presser foot ① backward in the oval hole.

NOTE: For normal sewing, align the presser with the reference line.

## Adjusting the upper feed pressure

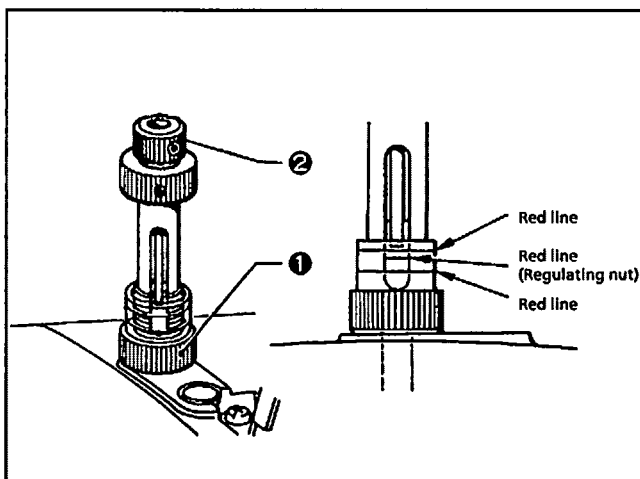

The standard upper feed pressure is obtained when the red line of the regulating nut ② is between the two red lines of the pressure regulating dial ①.

By rotating the regulating nut ②, adjust the upper feed pressure so that the upper feed dog feeds the material securely.

NOTE: The stronger the upper feed pressure, the more the upper feed efficiency increases. However, if the upper feed is too strong, the upper feed dog pushes up the presser, and the material slips. Be sure to adjust the pressure within the two red lines of the presser regulating dial ①.



## 8 Adjusting thread trimmer

### 1. Replacing the fixed knife and the movable knife

Turn off the power.

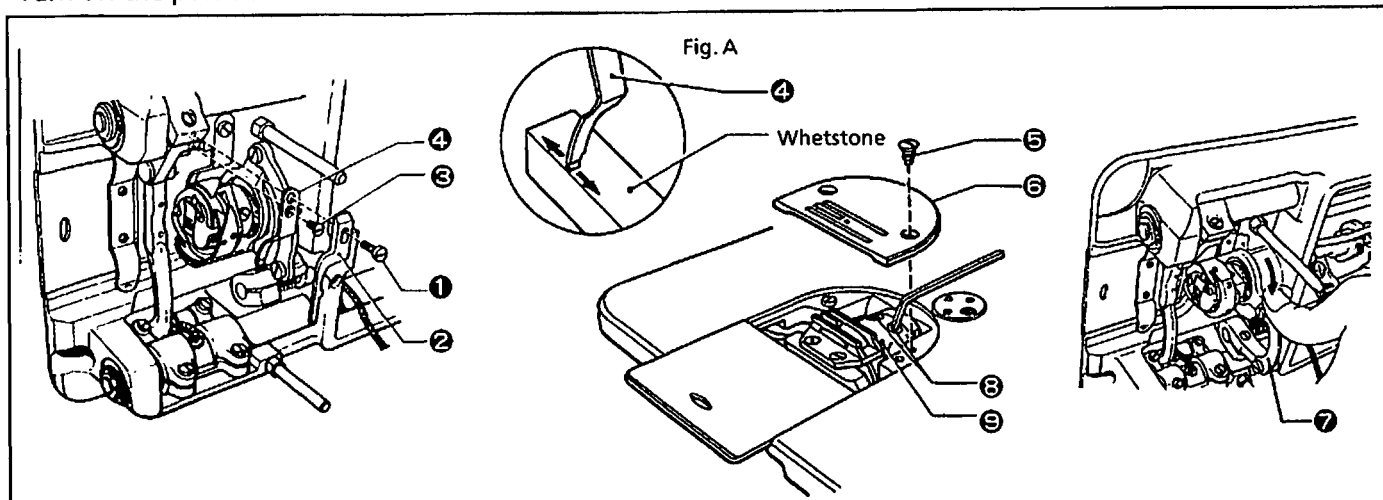

#### Removing the fixed knife

- 1) Tilt the machine head until it stops.
- 2) Remove the screw ① and the bobbin case holder position bracket ②.
- 3) Remove the screw ③ and the fixed knife ④.

NOTE: When the fixed knife ④ becomes blunt, sharpen it as illustrated in Fig. A.

#### Removing the movable knife

- 1) Lift the presser foot using the presser bar lifter.
- 2) Remove the screw ⑤ and the needle plate ⑥.
- 3) Turn the machine pulley until the needle bar is at its highest position.
- 4) Press the thread trimmer rod ⑦ manually in the direction of the arrow until the screws ⑧ become visible.
- 5) Remove the screws ⑧ and the movable knife ⑨.

NOTE: Before removing the needle plate ⑥ and the movable knife ⑨, remove the needle.

Reassembly is performed by reversing the above procedures.

### 2. Adjusting the fixed knife, movable knife, and the lower thread finger

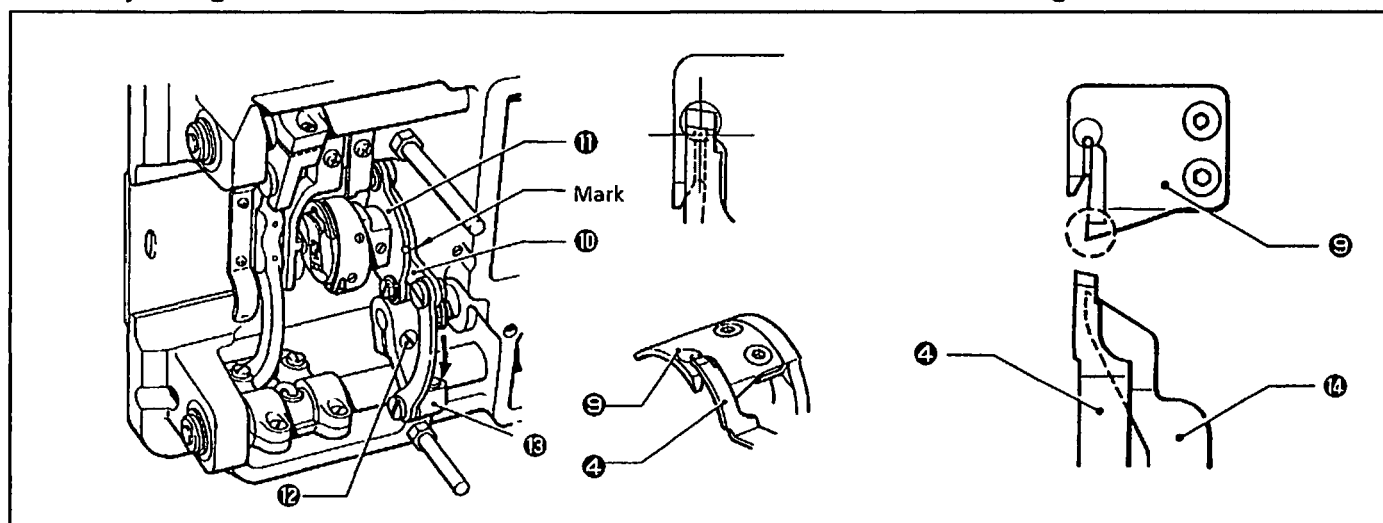

After attaching the movable knife ⑨ and the fixed knife ④, align the notch marks of the movable knife holder ⑩ and the knife holder presser ⑪ while pressing the thread trimmer rod ⑦. At this time, the movable knife ⑨ should overlap the fixed knife ④ tip for 1 mm.

If the knives do not overlap, loosen the screw ⑫ and adjust the thread trimmer lever ⑬.

NOTE: Slide the lower thread finger ⑭ to the movable knife ⑨ to give the proper gap between the lower thread finger ⑭ and the rotary hook.

## 9 Adjusting tension release

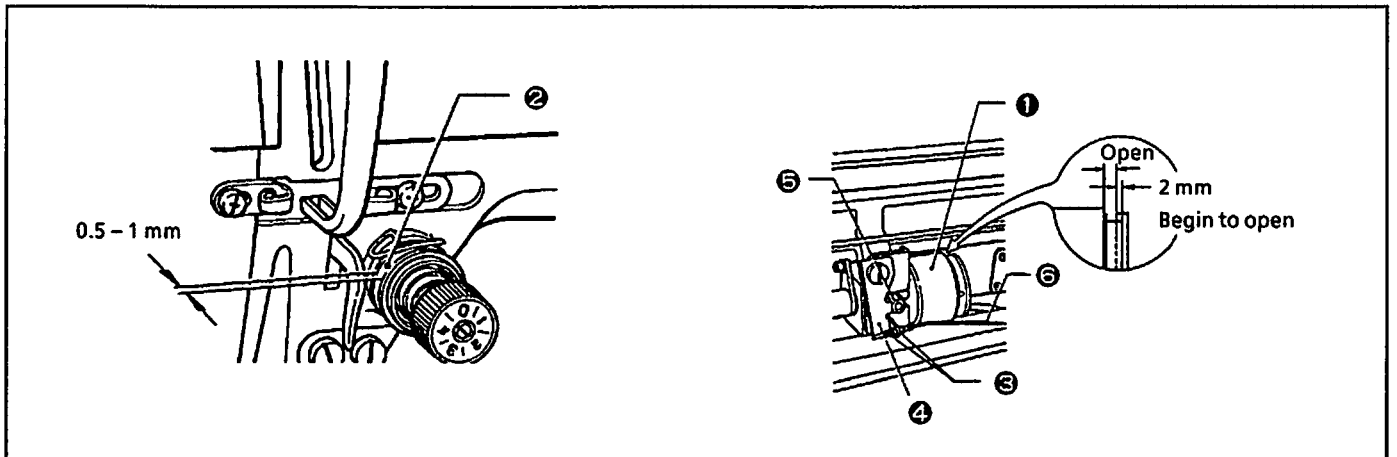

After thread trimming, if the needle thread escapes from the needle hole or if the tension discs do not close, make the following adjustment.

**A. If the thread escapes from the needle hole (Tension release does not function properly at thread trimming.)**

- 1) When the thread trimmer solenoid ① is depressed approximately 2 mm, the tension discs ② (tension releasing disc washers) begin to open. When the thread trimmer solenoid ① is fully depressed, the discs should open completely.
- 2) When the thread trimmer solenoid ① is released, the tension discs ② should close.
- 3) Loosen the nut ⑤, then depress the thread trimmer solenoid ① approximately 2 mm.
- 4) Tighten the nut ⑤ (left side) at the point where the tension discs ② begin to open.  
Check that the tension discs ② open when the thread trimmer solenoid ① is fully depressed, and that the discs ② close when the solenoid ① is released.

**B. If the tension discs do not close**

- 1) Check if the tension releasing lever ④ is retracted.
- 2) Check if the tension releasing spring ⑤ is attached.
- 3) Check if the tension releasing wire ⑥ is taut.

(The three check points above can be adjusted with the nut ⑤. If they cannot be adjusted, replace the tension releasing wire ⑥.)

## 10 Adjusting thread tension

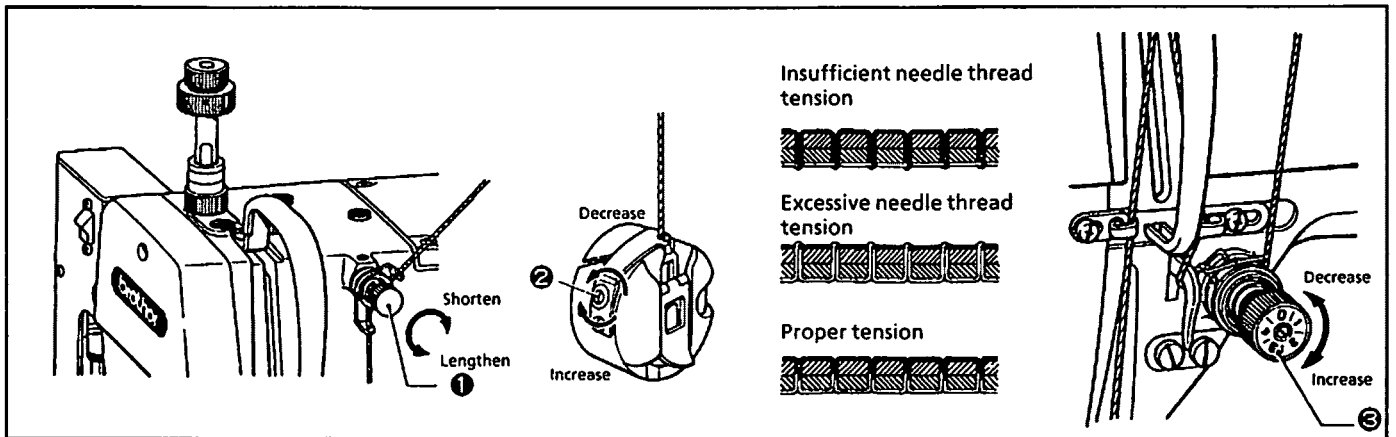

After thread trimming, adjust the thread leader to 35-40 mm by turning the screw ①.

Adjust the bobbin thread tension by turning the spring adjusting screw ② so that the bobbin case does not slip down of its own weight from the bobbin thread when it is suspended by the bobbin thread.

After lowering the presser foot, adjust the needle thread tension by turning the nut ③.

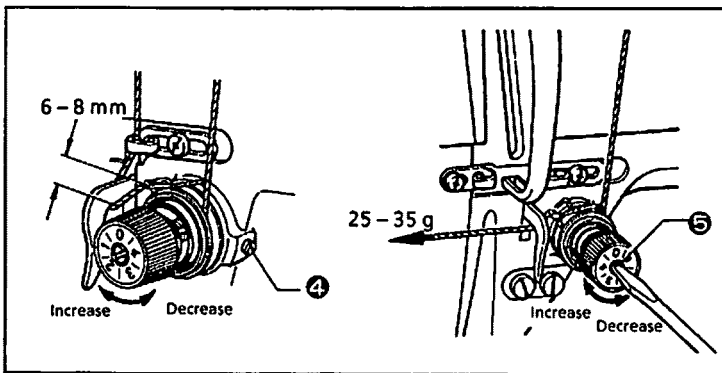

### Thread take-up spring

The standard operation height of the thread take-up spring is 6-8 mm. To adjust the height, loosen the screw ④ then turn the upper tension regulator assembly.

The standard tension of the thread take-up spring is 25-35 g. To adjust the tension, rotate the tension stud ⑤ using a screwdriver.

## 11 Adjusting synchronizer (DB2-B774)

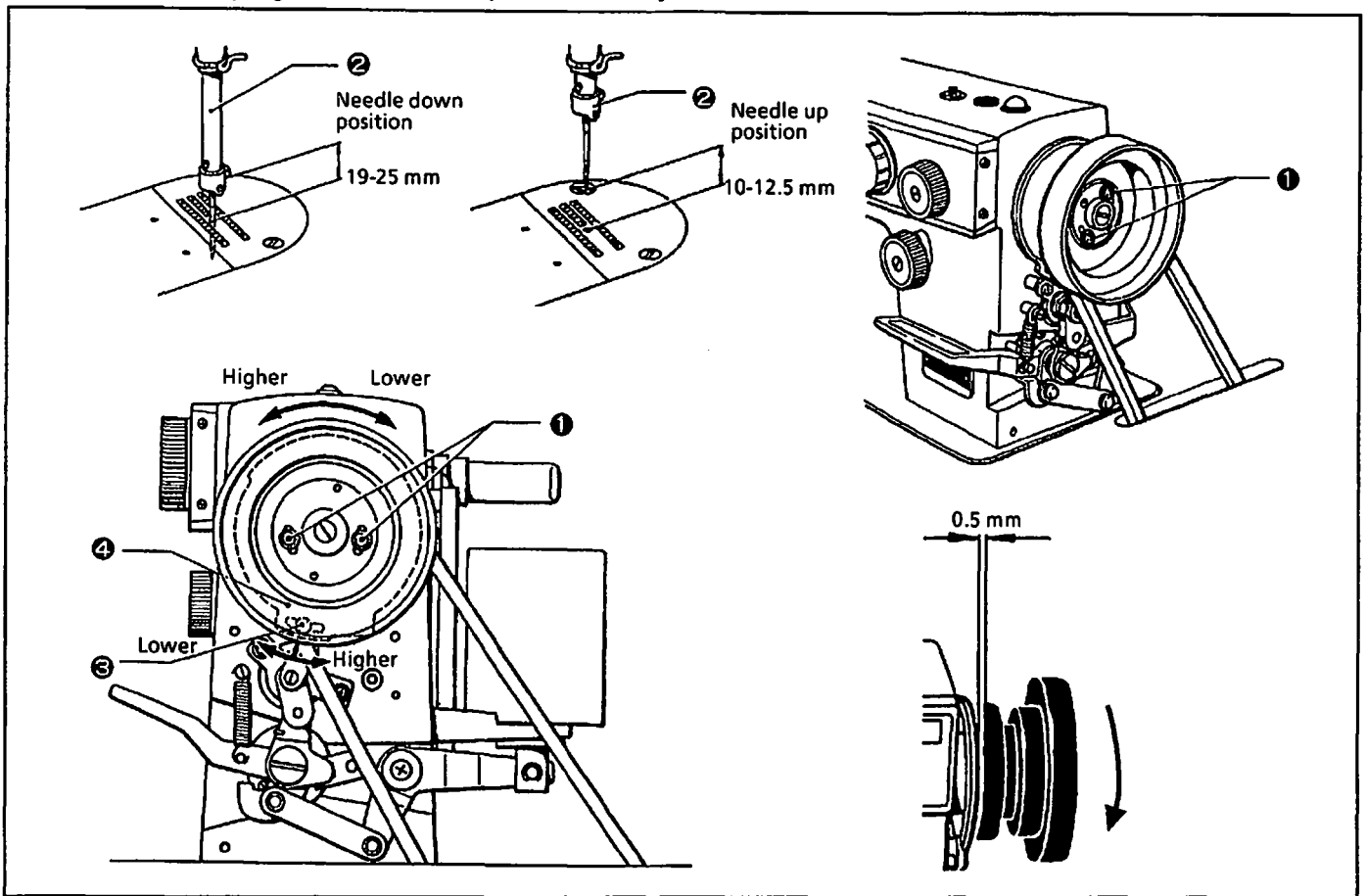

- 1) The two elements in the synchronizer monitor the needle position. The thread trimming signal is sent by two signals – the needle down signal and the heel back signal.
- 2) After turning on the power and then stopping the machine at the needle down position, there should be a 19-25 mm gap between the needle plate's upper surface and the bottom edge of the needle set screw. When stopping the machine at the needle up position, there should be a 10-12.5 mm gap between the needle plate's upper surface and the needle tip when the pulley reference line is in the range of the belt cover reference line.  
If the adjustment is necessary, refer to the following.
- 3) Be sure to turn off the power before adjustment.

### Adjusting the needle up position

- 1) Loosen the two screws ❶.
- 2) To raise the needle bar ❷, rotate the screws ❶ in the direction of normal pulley rotation.  
To lower the needle bar ❷, rotate the screws ❶ in the opposite direction.

### Adjusting the needle down position (DB2-B774)

- 1) Press the pedal then release it. (The needle will stop at its down position.)
- 2) Check that there is 19-25 mm gap between the needle plate's upper surface and the bottom edge of the needle set screw.  
NOTE: In model B7740, check that the needle bar stops 2.7 mm above its lowest position.
- 3) If the gap is not 19-25 mm, loosen the screw ❸, then shift the synchronizer assembly ❹ to adjust it.  
NOTE: Check the adjustment of the needle up position.

## 12 Adjusting thread wiper

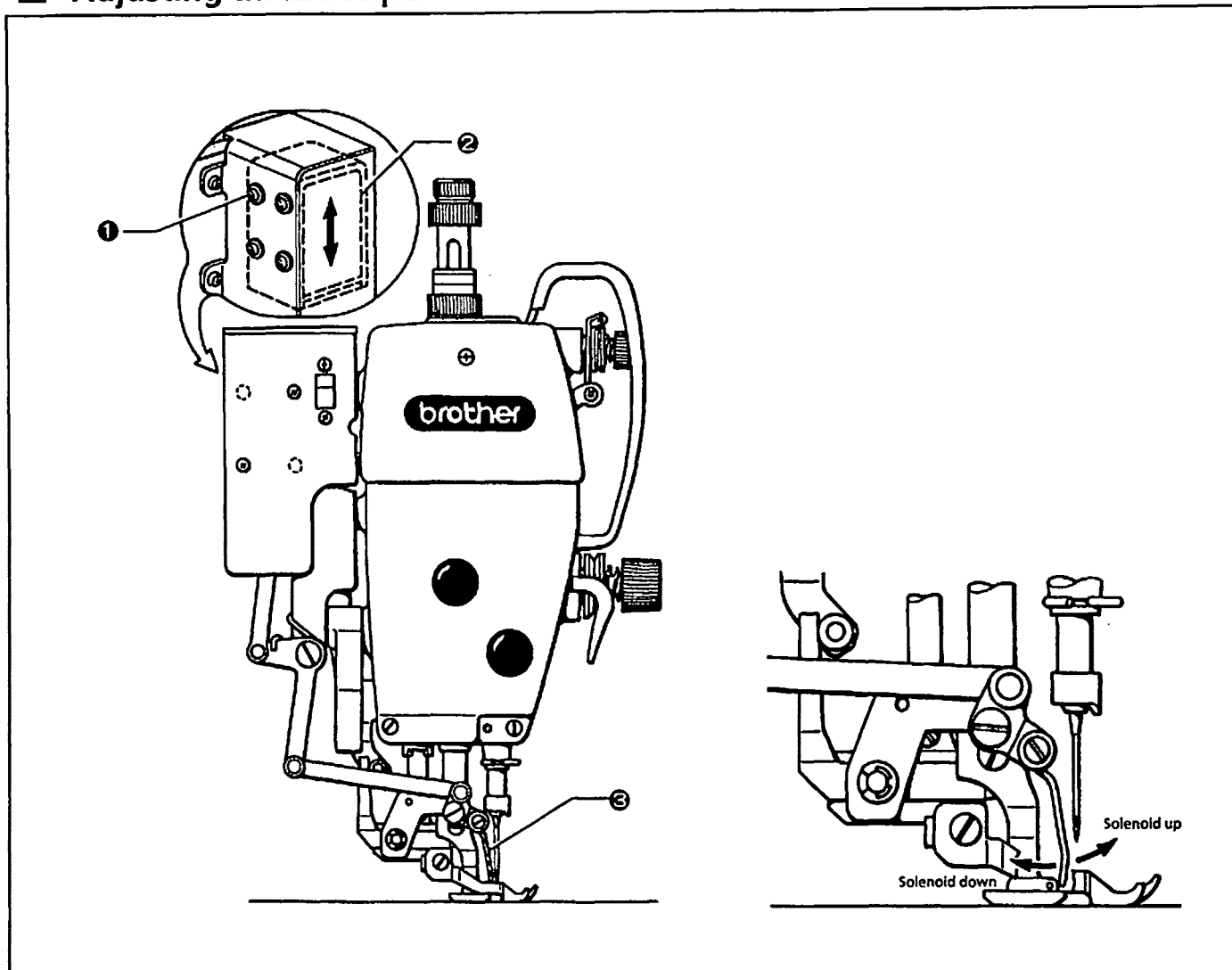

- 1) Loosen the four screws ❶. Move the thread wiper solenoid ❷ up and down and adjust its position so that the tip of thread wiper ❸ does not strike the upper feed dog, presser foot, needle, and any other part.
- 2) After adjustment, tighten the screws ❶.

## 13 Adjusting potentiometer (B7740)

The feed dog height is set 0.8mm prior to shipping from the factory.  
If the feed dog height is not 0.8 mm, the indicated pitch will be inaccurate.

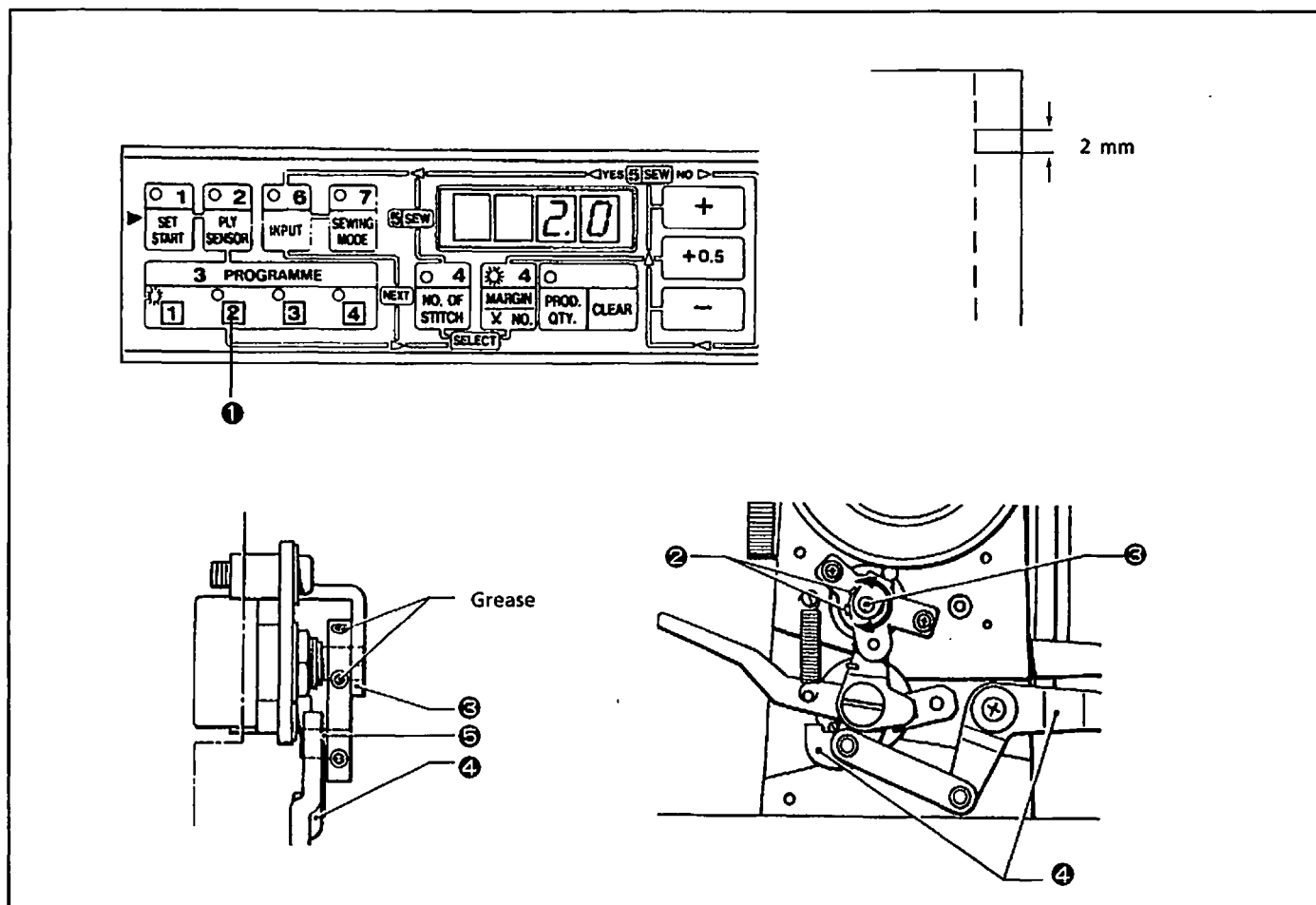

- 1 When PROGRAMME key No.2 ❶ is pressed while indicators No.1, 2, 6 and 7 are off (normal sewing mode), the pitch is indicated on the display.
- 2 Make sure the actual pitch is the same as the indicated one (the actual pitch does not match with the indicated one if the feed dog height is changed). If it is different, adjust the potentiometer following the procedures below.

### Adjustment

- 1) After loosening the two screws ❷, rotate the potentiometer assembly ❸. Tighten the screws ❷ temporarily. The indicated number is decreased when the potentiometer ❸ is rotated clockwise.
- 2) Sew several stitches and check that the actual pitch matches the indicated one.
- 3) Repeat 1) and 2) to match the indicated pitch with the actual pitch.
- 4) After the indicated pitch is matched, tighten the screws ❷.

NOTE: Apply a small amount of grease on the branch of the potentiometer lever plate assembly ❹ and on the potentiometer pin ❺

NOTE: Replace potentiometer assembly ❸ all together (code:S06067-001).

## 14 Checking feed mechanism weight (B7740)

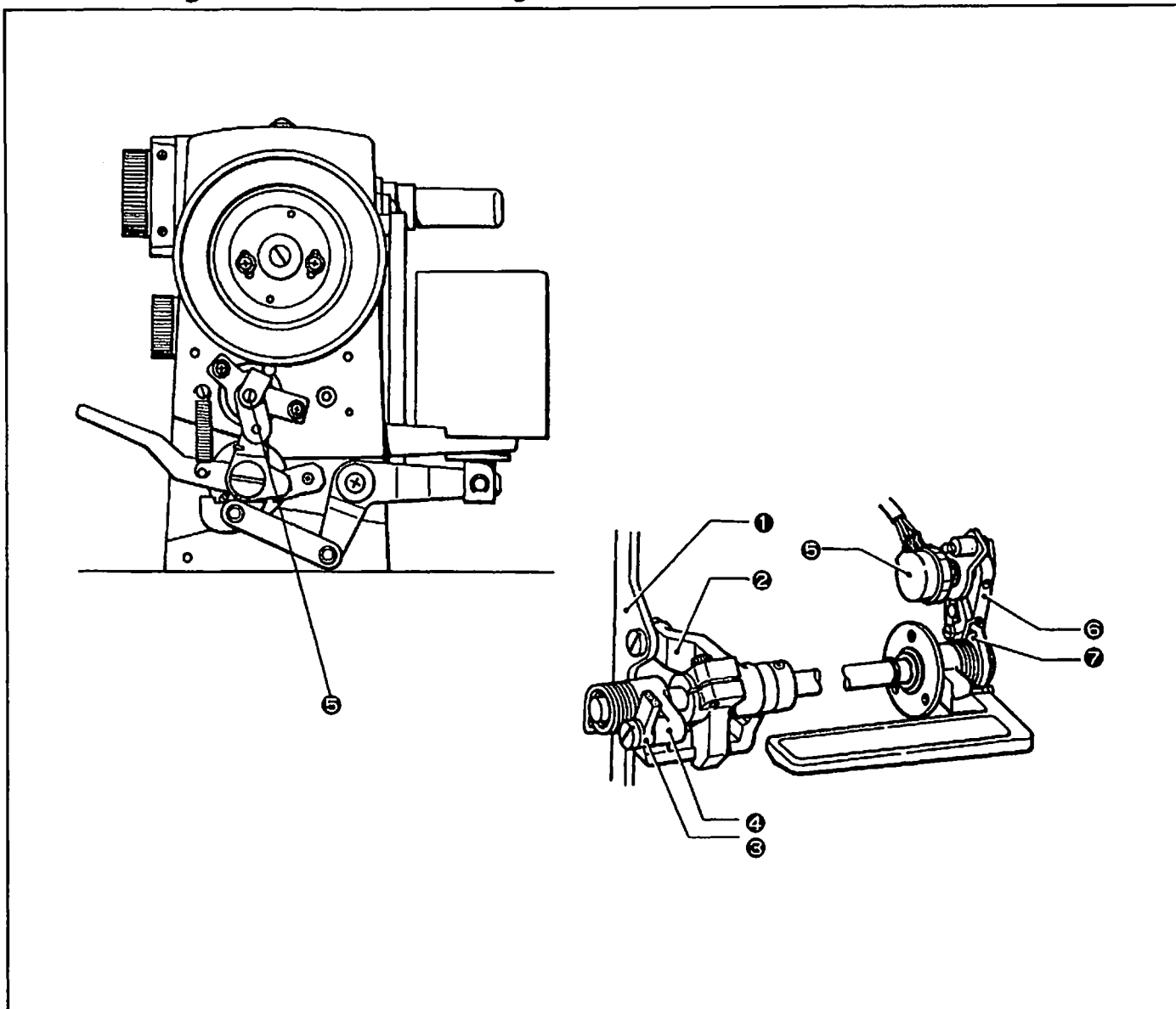

Raise the presser foot and then set the feed regulating dial to its maximum.

Check that the reverse lever returns to its original position by itself after pushing the reverse lever down slowly.

If it does not, check the following points:

- 1) The feed regulator connecting rod ① and the feed regulator lever (lower) ② are attached properly.
- 2) The feed regulator connecting rod (upper) ③ and the feed regulator lever (upper) ④ are attached properly.
- 3) The potentiometer ⑤ and the potentiometer lever ⑥ are attached properly.
- 4) The branch of the potentiometer lever plate assembly ⑦ and the potentiometer lever ⑥ are attached properly.

The reverse lever could get stiff and might not return because of the reasons above.

## 15 Adjusting sensor position

The photo-cell position needs to be adjusted when the reflector position is changed.

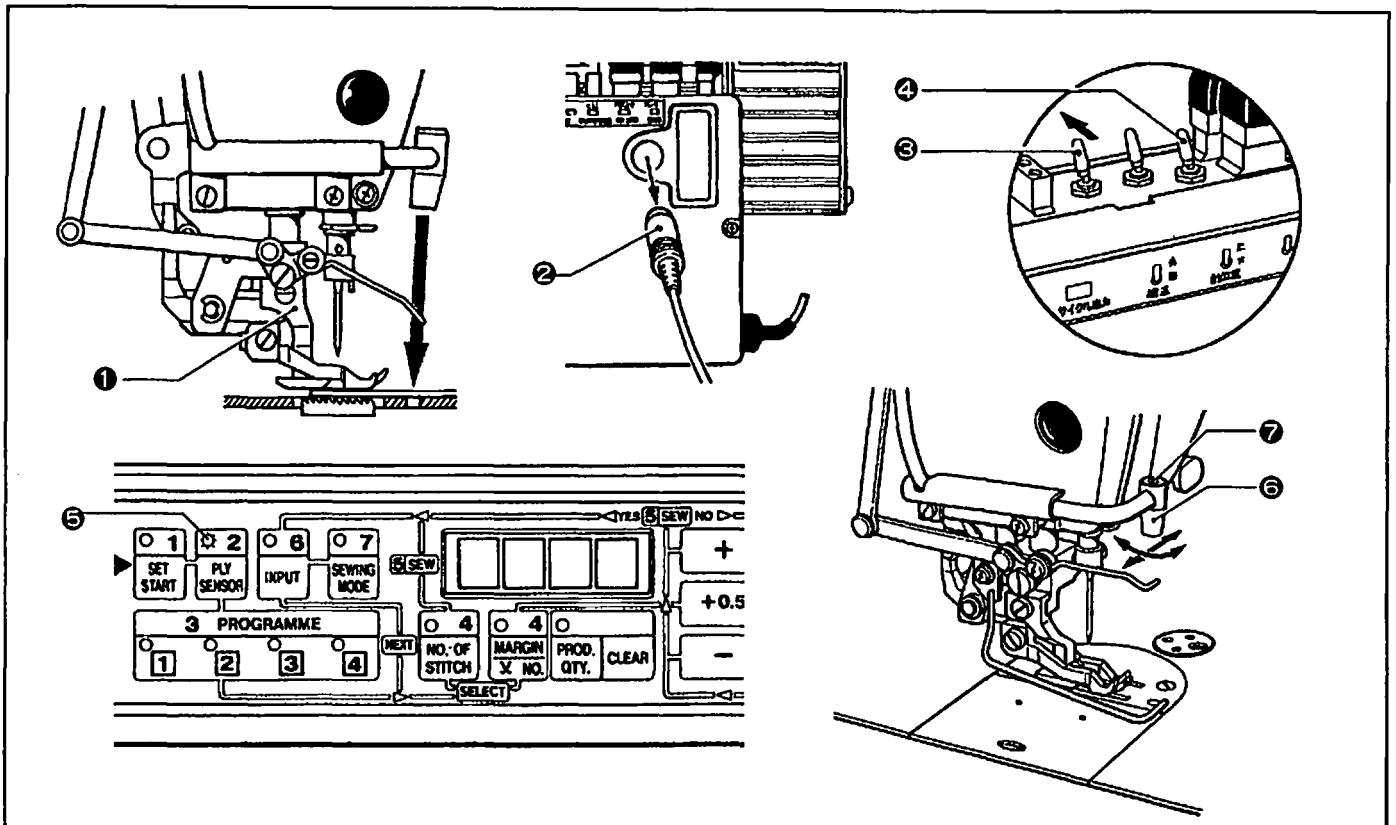

- 1) Turn off the power.
- 2) Set a material under the presser foot ① (under the sensor).  
NOTE: The photo-cell position might not be properly adjusted without materials.
- 3) Disconnect the synchronizer cord ②.
- 4) Set the correction switch ③ to ON.
- 5) Set the sensitivity control switch ④ to THIN.
- 6) Turn on the power. The ply sensor indicator ⑤ should blink.  
Adjust the position of the photo-cell ⑥ so that the number indicated on the display is at its maximum. The number should be at least 1260 (1260 is indicated when no material is on the presser foot).

### Adjustment

- 1) Move the photo-cell ⑥ slightly right and left or back and forth by loosening the screw ⑦.
- 2) Secure the photo-cell ⑥ with the screw ⑦ when the indicated number is at its maximum.  
NOTE: It takes about 5 seconds to indicate the number.  
NOTE: After adjustment, turn off the power. Connect the synchronizer cord ② and set the correction switch ③.

### Cautions for attaching the sensor guard

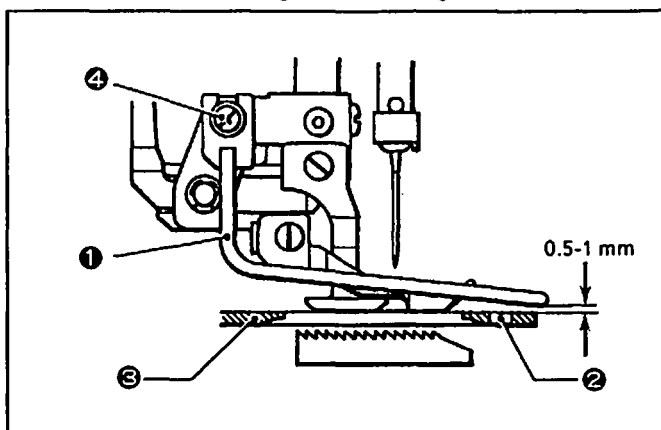

The sensor guard ① is used to prevent fingers from getting into the reflector case (right) ② and to prevent materials from getting uneven.

When the feed dog is under the needle plate, adjust the gap between the upper surface needle plate ③ and the bottom of the sensor guard ① to 0.5-1 mm, using the screw ④.

NOTE: The machine may not stop if fingers are put in the sensor.



## 16 Adjusting the indication of the distance between needle hole and sensor (B7740)

Match the actual distance between the needle hole and the sensor with the indicated number on the display, if the sensor position is changed.

The distance measurement is necessary to stop at a material edge.

The machine does not stop at a material edge without this adjustment.

The distance is measured when the feed amount is 0.

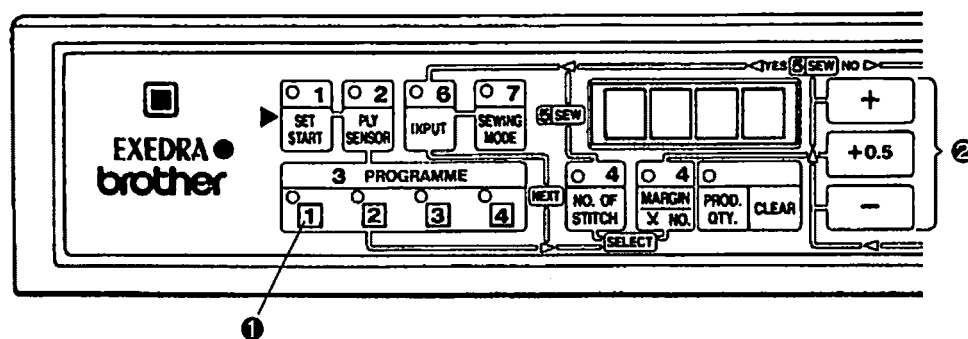

- 1) The distance is indicated when PROGRAMME key No.1 ① is pressed, while indicators No.1, 2, 6 and 7 are off (normal sewing mode).
- 2) At this time, the number can be changed using the [+], [0.5] or [-] keys ② to match it with the actual pitch.

The distance between the needle hole and the sensor

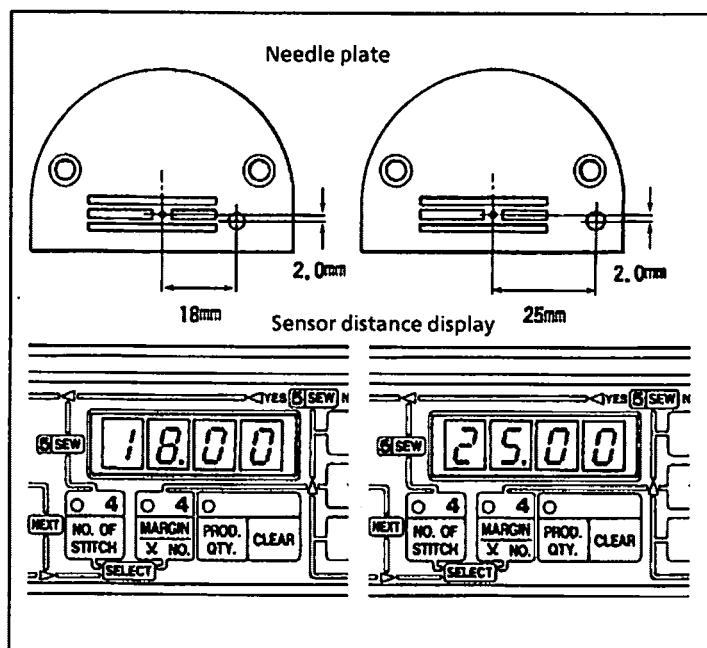

When drilling a sensor hole on a needle plate that is available on the market, measure the distance between the needle hole and the sensor in order to indicate it on the display.

Example: change the distance 25 mm to 18 mm.

- 1) Set indicators No.1, 2, 6 and 7 to off.
- 2) Press PROGRAMME key No.1 to indicate 25.00.
- 3) Change the number by pressing the [-] key continuously until it is 18.00. (Press the [0.5] key or [+] key in order to increase the numbers.)
- 4) Press PROGRAMME key No.1 to make the number disappear.

## REPLACEMENTS

### 1 Replacing Solenoids

Remember where the solenoid cords are attached when disconnecting them. Attachment is done in the reverse order of the removal.

#### 1. Thread trimmer solenoid

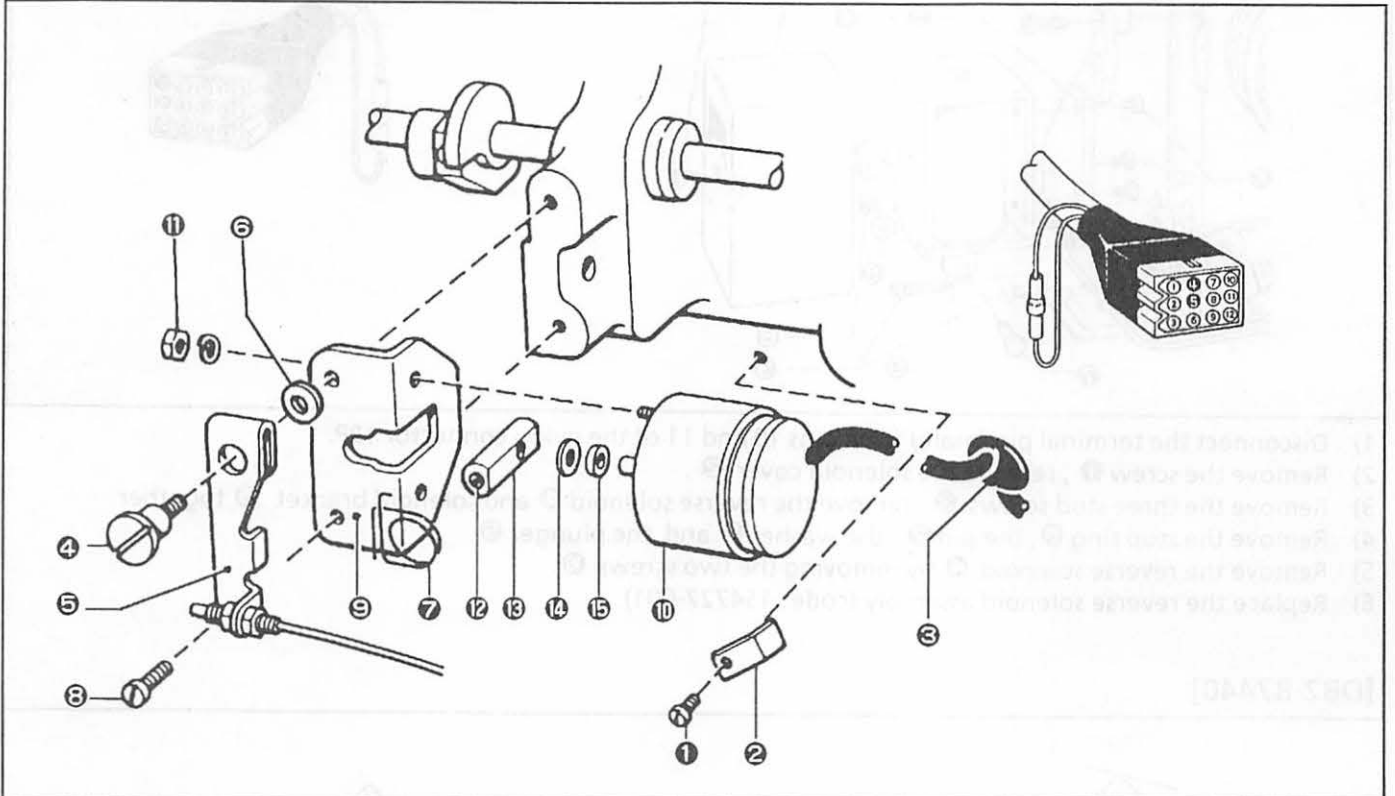

- 1) Disconnect the terminal pin (male) from pins 4 and 5 of the nylon connector 12P.
- 2) Tilt the machine head until it stops.
- 3) Loosen the screw ①. Disconnect the cord from the cord holder ②.
- 4) Remove the cord from the cord bushing ③.
- 5) Remove the stud screw ④, the tension release lever ⑤, the washer ⑥, and the tension release spring ⑦.
- 6) Remove the screw ⑧ to remove the thread trimmer solenoid bracket ⑨ along with the thread trimmer solenoid ⑩.
- 7) Remove the thread trimmer solenoid ⑩ by removing the two nuts ⑪.
- 8) Remove the solenoid lever ⑬, the washer ⑭ and the cushion ⑮ by loosening the screw ⑫.
- 9) Replace the thread trimmer solenoid (code: 502815-001).

## 2. Reverse solenoid

[DB2-B744]

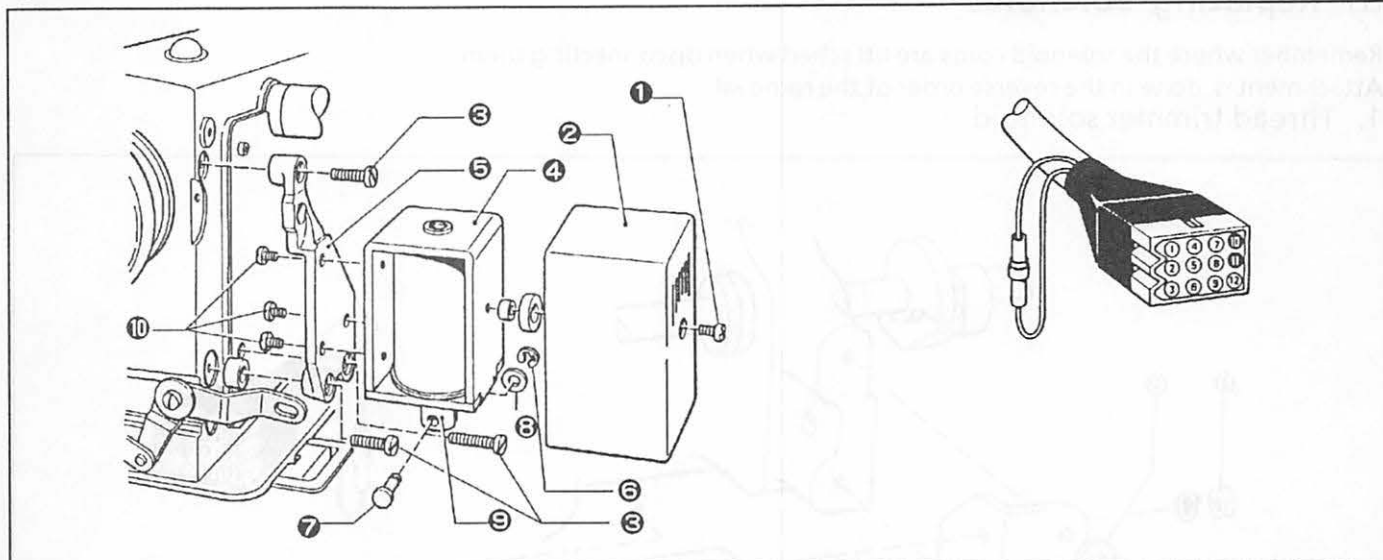

- 1) Disconnect the terminal pin (male) from pins 10 and 11 of the nylon connector 12P.
- 2) Remove the screw ①, remove the solenoid cover ②.
- 3) Remove the three stud screws ③, remove the reverse solenoid ④ and solenoid bracket ⑤ together.
- 4) Remove the stop ring ⑥, the pin ⑦, the washer ⑧ and the plunger ⑨.
- 5) Remove the reverse solenoid ④ by removing the two screws ⑩.
- 6) Replace the reverse solenoid assembly (code: 154727-001).

[DB2-B7440]

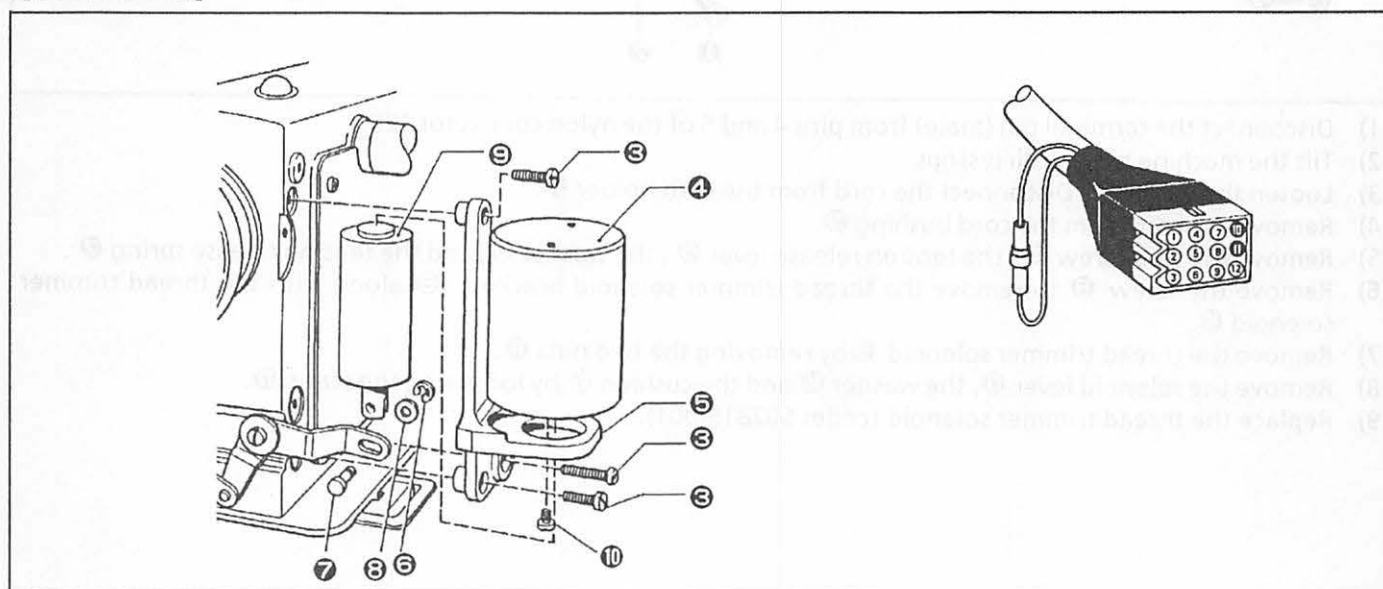

- 1) Disconnect the terminal pin (male) from pins 10 and 11 of the nylon connector 12P.
- 2) Remove the three screws ③ to remove the reverse solenoid ④ and the solenoid bracket ⑤.
- 3) Remove the stop ring ⑥, the pin ⑦, the washer ⑧ and the plunger ⑨.
- 4) Remove the reverse solenoid ④ by removing the two screws ⑩.
- 5) Replace the reverse solenoid assembly (code: S11179-001).

### 3. Thread wiper solenoid, thread wiper switch

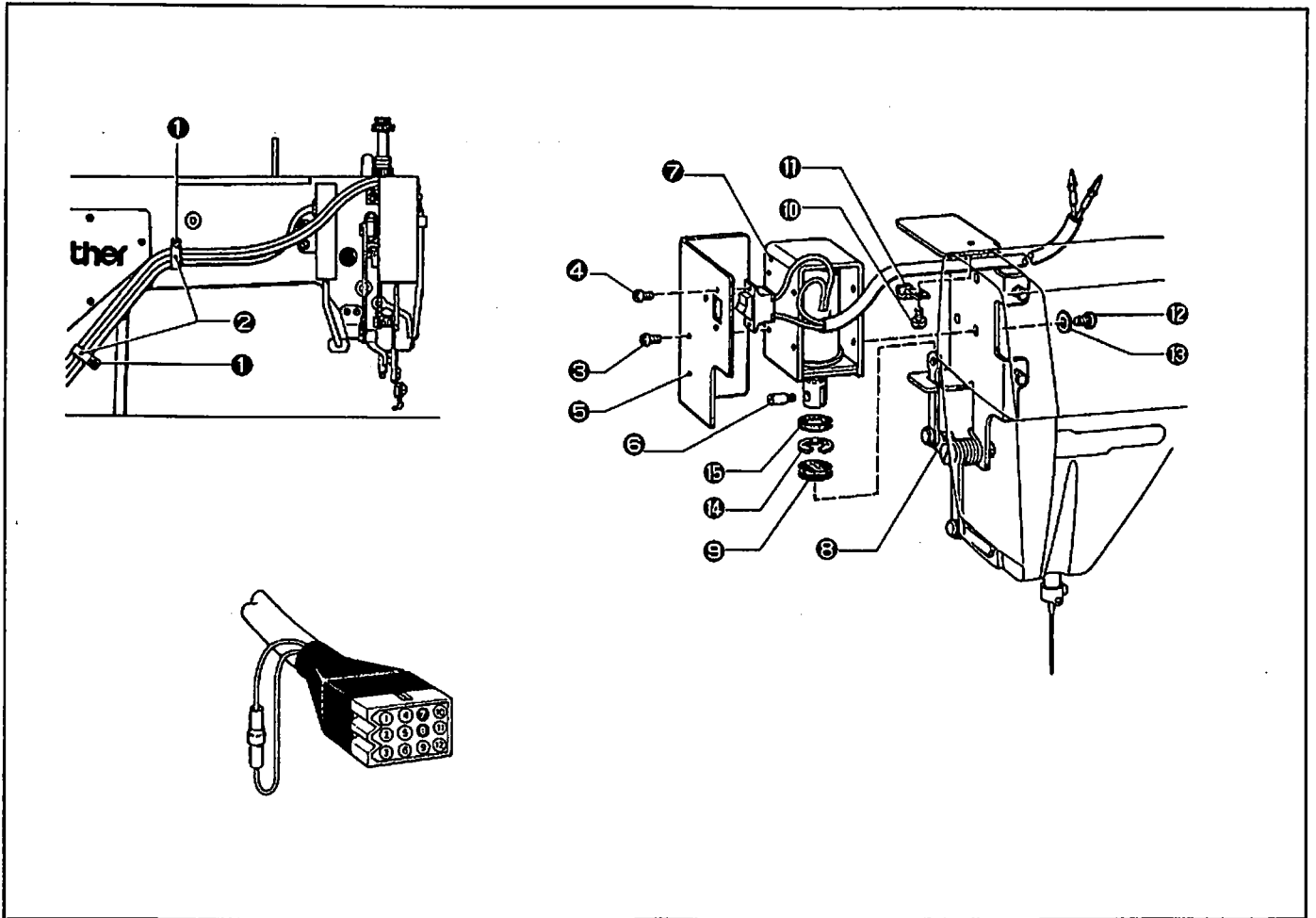

#### Thread wiper solenoid

- 1) Disconnect the terminal pin (male) from pins 7 and 8 of the nylon connector 12P.
- 2) Remove the cords from the two cord holders 2 by loosening the two screws 1.
- 3) Remove the solenoid cover 5 by removing the two screws 3 and 4.
- 4) Remove the plunger pin 6, remove the thread wiper link assembly 8 from the thread wiper solenoid 7. Remove the rubber stopper 9.
- 5) Loosen the screw 10, disconnect the cord from the cord holder 11.
- 6) After removing the four screws 12 and the washer 13, remove the thread wiper solenoid 7.
- 7) Disconnect the plunger of the thread wiper solenoid 7. Remove the stop ring 14 and the plunger rubber 15.
- 8) Replace the thread wiper solenoid assembly (code: S02799-001).

#### Thread wiper switch

- 1) Remove the solenoid cover 5.
- 2) Replace the thread wiper switch.

## 2 Replacing tension release wire

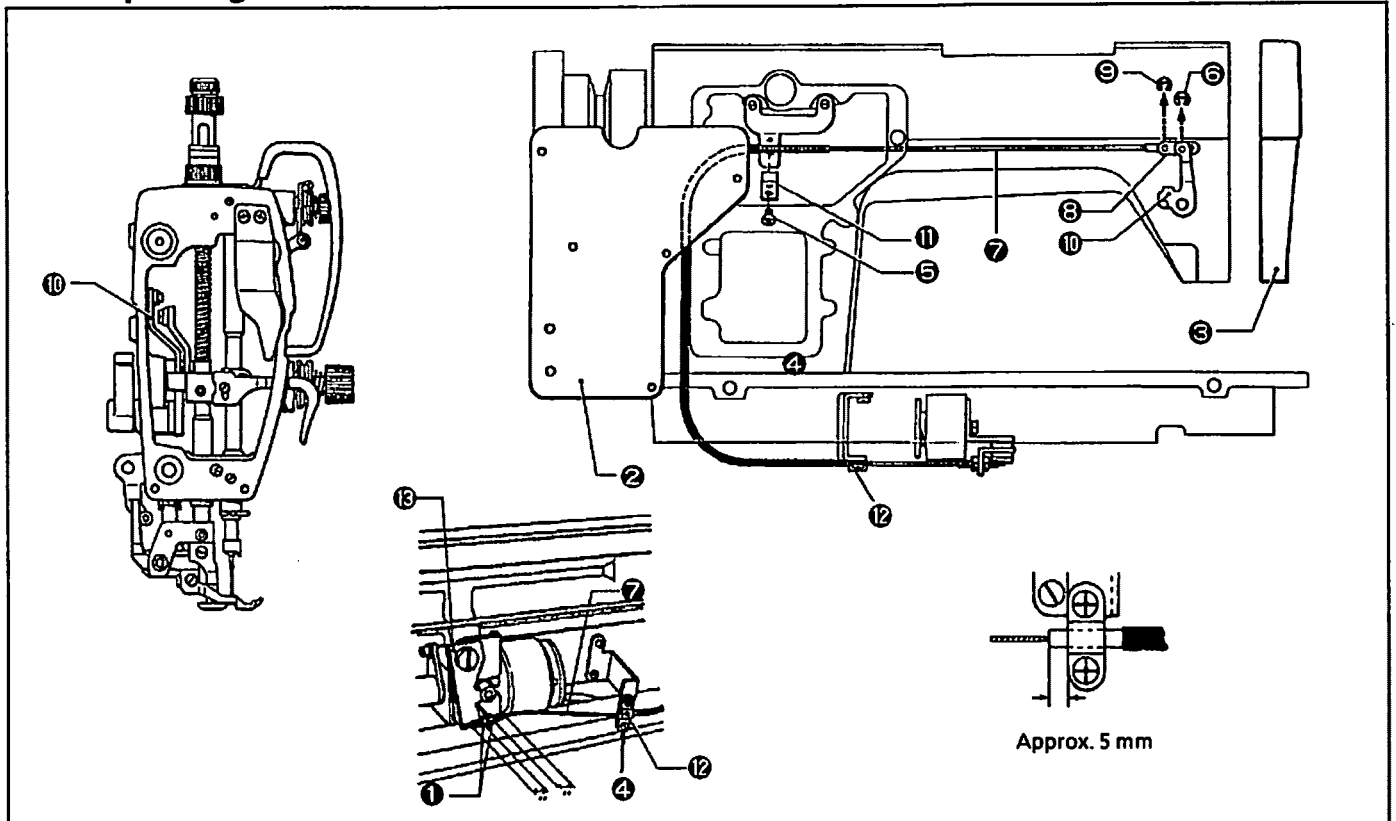

### Removal

- 1) Remove the nut ①.
- 2) Remove the rear cover ②.
- 3) Remove the face plate ③.
- 4) Loosen the screws ④ and ⑤.
- 5) Remove stop ring E ⑥. Remove the tension release wire ⑦ and the tension release link assembly ③.
- 6) Remove stop ring E ⑥ from the tension release wire ⑦ and remove the tension release link assembly ③.
- 7) Replace the tension release wire (code:154682-001).

### Attachment

- 1) Attach the tension release link assembly ③ to the tension release wire ⑦ with stop ring E ⑥.
- 2) Thread the tension release wire ⑦.
- 3) Attach the tension release link assembly ③ to the tension release plate ⑩ with stop ring E ⑥.
- 4) Secure the tension release wire ⑦ with the tension release wire presser (upper) ⑪. Fasten the screw ⑤.
- 5) Secure the tension release wire ⑦ with the tension release wire presser (lower) ⑫. Fasten the screw ④.
- 6) Insert the tension release wire ⑦ into the thread release lever ⑬ and secure with the nut ①.

## 3 Replacing bobbin tension spring

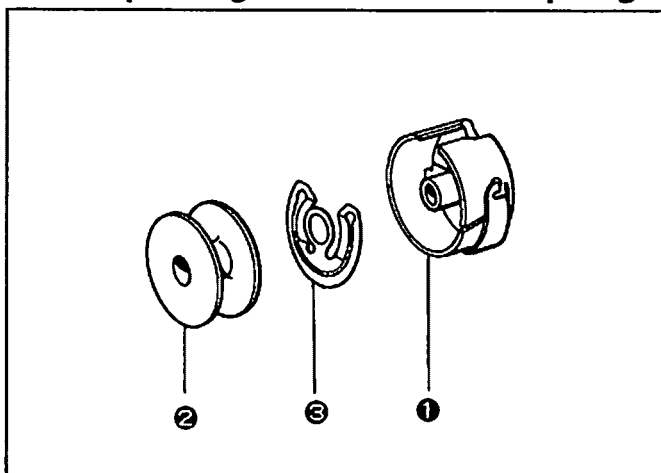

- 1) Remove the bobbin case ① from the machine.
- 2) Remove the bobbin ② from the bobbin case ①.
- 3) Remove the bobbin tension spring ③ from the bobbin case ① using a screwdriver.
- 4) Replace the bobbin tension spring (code:S03246-001).

## 4 Replacing photo-cell and reflector (B7740)

### Cautions for replacing the sensor

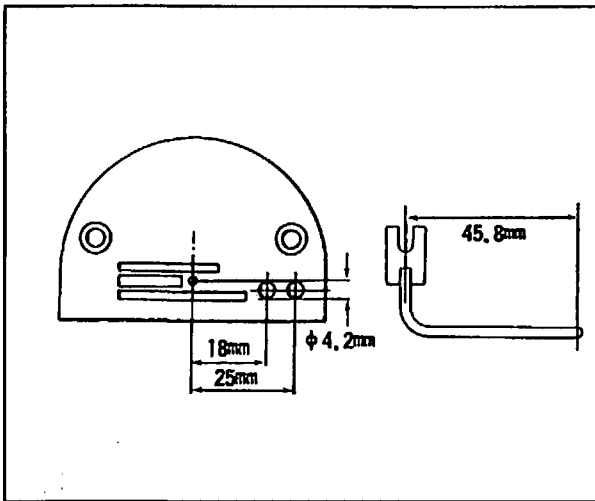

The distance between the needle hole and the sensor can be changed within the range of 18-25 mm.

Be sure to change the photo-cell and reflector together.

Do not damage the cover when removing the needle plate .

There are two types of sensor guards: one is for sensors whose distance to the needle hole is 18 mm. The other is for sensors whose distance to the needle hole is 25 mm.

Drill a sensor hole with a diameter of 4.2 mm on a needle plate that is available on the market.

### 1. Replacing photo-cell

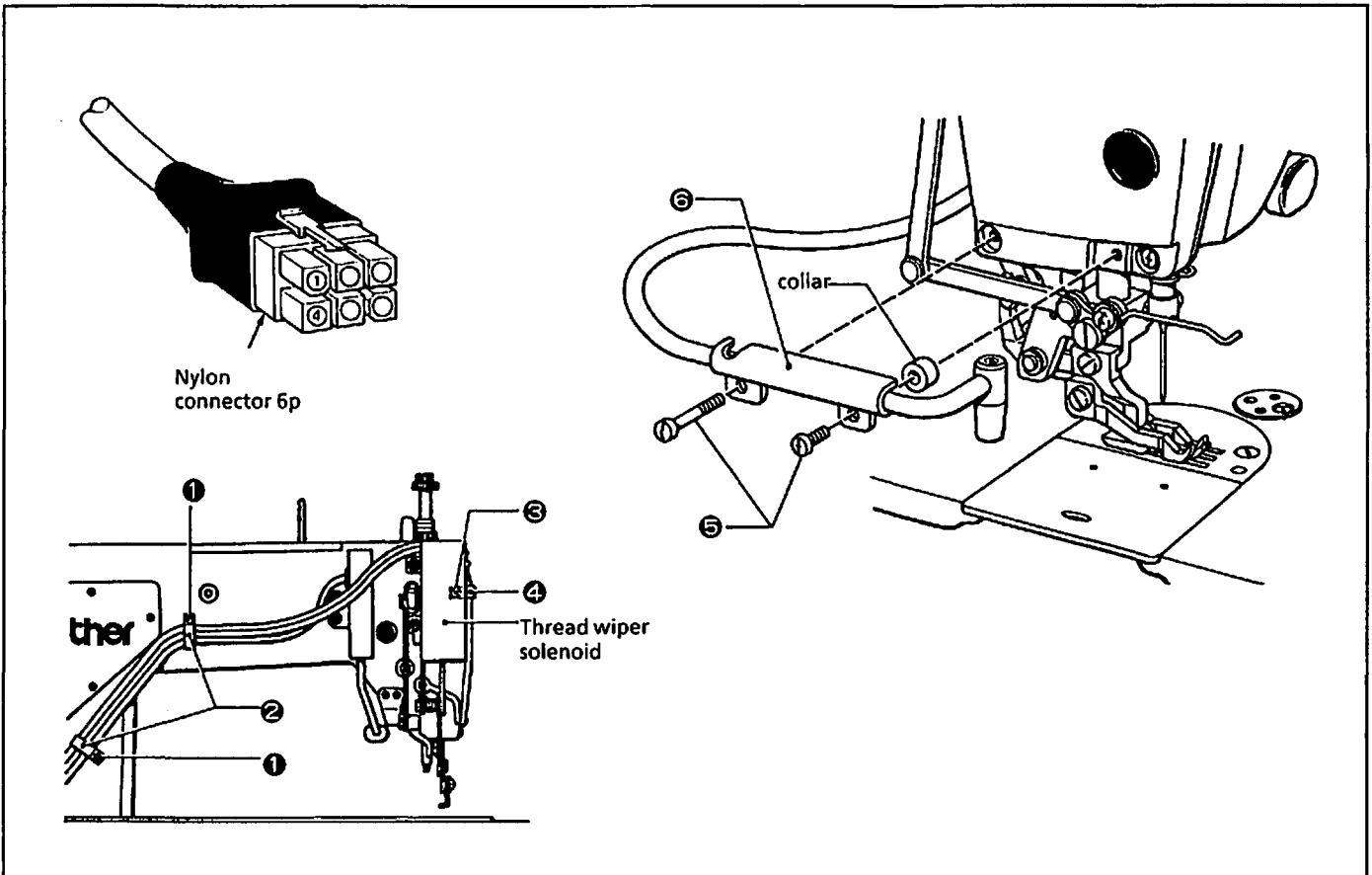

- 1) Disconnect the terminal pin (male) from pins 1 (white) and 4 (black) of the nylon connector 6P.
- 2) Remove the cords from the two cord holders ② by loosening the two screws ①.
- 3) Remove the cord from the cord holder spring ④ by loosening the screw ③.
- 4) Remove the cord and the photo-cell ⑥ by loosening the two screws ⑤.
- 5) Replace the photo-cell (code : 183511-101).

NOTE: Attachment is done in the reverse order of the removal .

NOTE: After attaching the photo-cell and the reflector, adjust the sensor position and the distance between the needle hole and the sensor.

## 2. Replacing reflector

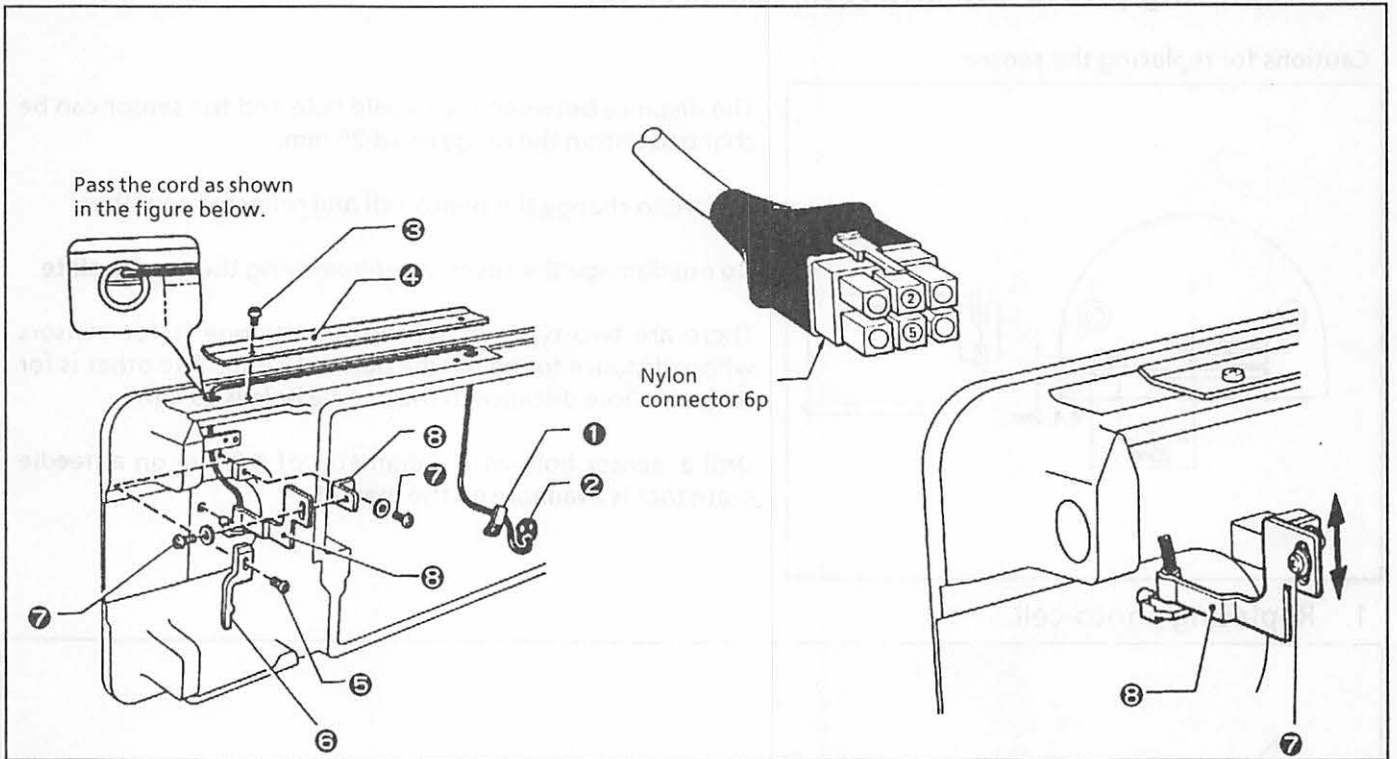

- 1) Remove the needle by loosening the screw.
- 2) Remove the sensor guard and the presser foot by loosening the screw.
- 3) Remove the slide plate.
- 4) Remove the needle plate by removing the screw.
- 5) Disconnect the terminal pin (male) from pins 2 (white) and 5 (black) of the nylon connector 6P.
- 6) Tilt the machine head until it stops.
- 7) Remove the reflector cord from the the cord holder ①.
- 8) Remove the reflector cord from the the cord bushing ②.
- 9) Remove the cord holder (lower) ④ by removing the two screws ③.
- 10) Remove the bobbin case holder position bracket ⑥ by removing the screw ⑤.
- 11) Remove the reflector ⑧ by removing the two screws ⑦.
- 12) Replace the reflector.

NOTE: Attachment is done in the reverse order of the removal .

NOTE: Do not extend the cover above the needle plate upper surface .

NOTE: After attaching the photo-cell and the reflector, adjust the sensor position and the distance between the needle hole and the sensor.

## 5 Replacing Synchronizers

Remove the belt cover if it is fixed.

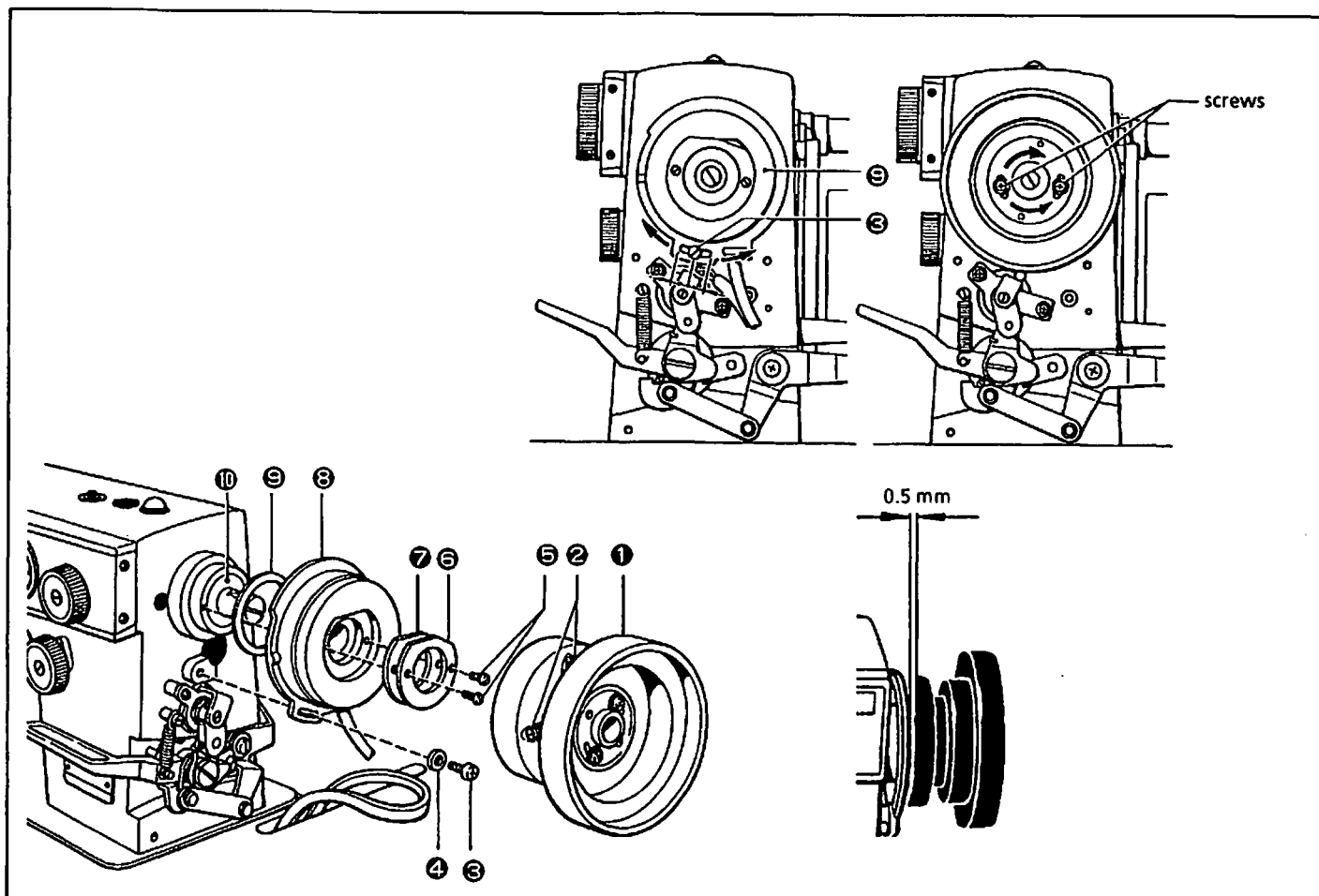

### Removal

- 1) Disconnect the synchronizer plug from the motor.
- 2) Remove the V-belt from the machine pulley ①.
- 3) Remove the pulley ① by loosening the two screws ②.
- 4) Remove the screw ③ and washer ④.
- 5) Remove the two screws ⑤, the synchronizer supporter ⑥, the packing ⑦, the synchronizer assembly ⑧ and the packing ⑨.
- 6) Replace the synchronizer assembly ⑦ (code: 228475-000).

### Attachment

- 1) Place the packing ⑨ and the synchronizer assembly ⑧ on the upper shaft bushing (right) ⑩.
- 2) Secure the synchronizer supporter ⑥ and the packing ⑦ with the two screws ⑤. (Make sure the synchronizer assembly ⑦ can be moved manually.)
- 3) Tighten the screw ③ and washer ④ temporarily at the middle of the long hole in the synchronizer .
- 4) Place the machine pulley ① on the upper shaft and secure it with the screws ②.  
(Of these screws ②, align the one which comes second when the pulley ① normally rotates with the screw stop of the upper shaft. Adjust the gap between the pulley and the synchronizer assembly to 0.5 mm.)
- 5) Put the V-belt on the machine pulley ①.
- 6) Connect the synchronizer plug with the motor.



## OPTIONAL EQUIPMENT

### 1 Thread wiper

The code of the thread wiper set is 183554-001.

Attaching the thread wiper

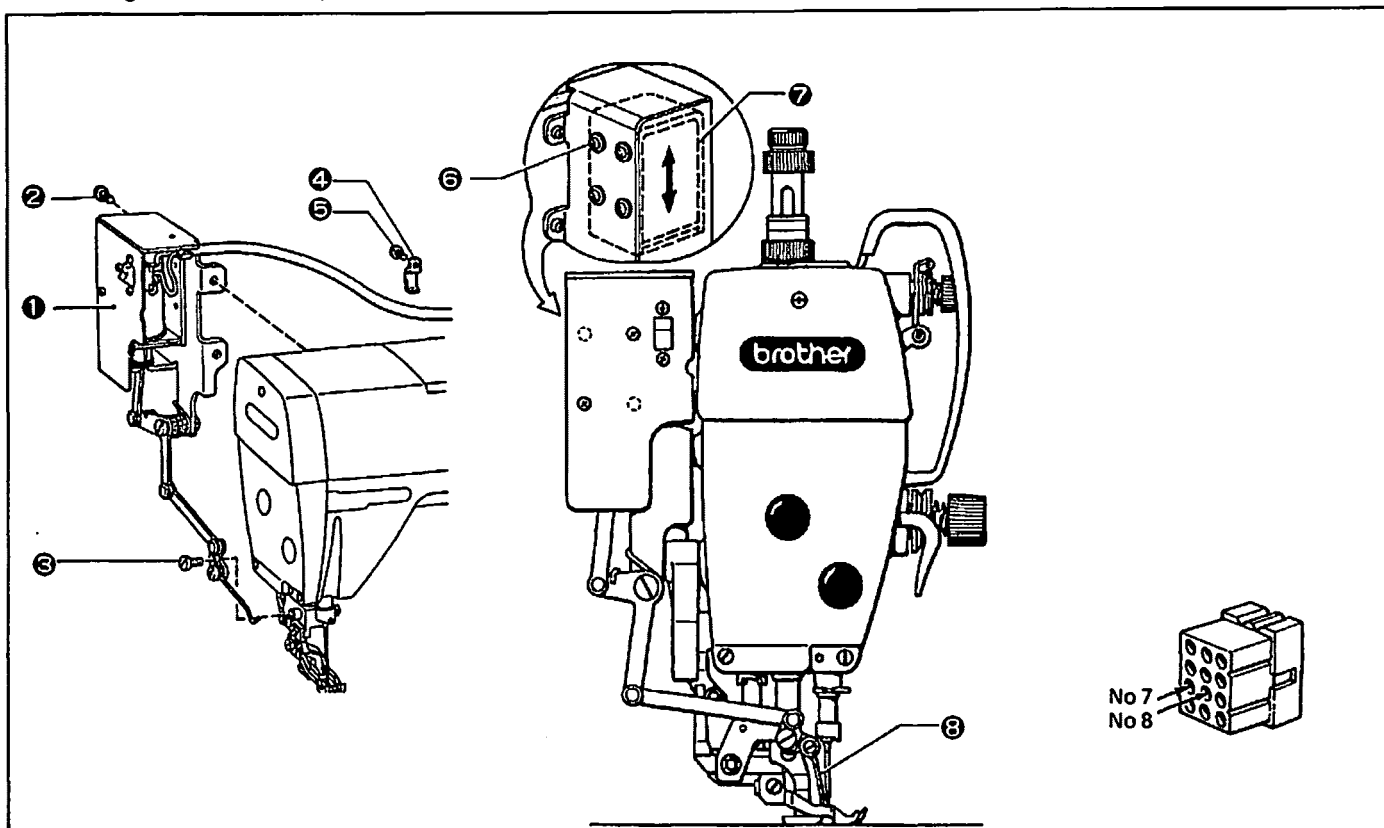

- 1) Attach the thread wiper solenoid assembly ① to the machine head with the screw ② and the stud screw ③.
- 2) Fasten the cord on the machine head using the cord holder ④ and the screw ⑤.
- 3) Connect the terminal pin (male) with pins 7 and 8 of the nylon connector 12p.

#### Adjusting the thread wiper

- 1) Loosen the four screws ⑥. Move the thread wiper solenoid ⑦ up and down and adjust its position so that the tip of thread wiper ⑧ does not strike the upper feed dog, presser foot, needle, and any other part.
- 2) After adjustment, tighten the screw ⑥.

## 2 Presser foot lifting solenoid set

Attaching the presser foot lifting solenoid set [subclass -003]

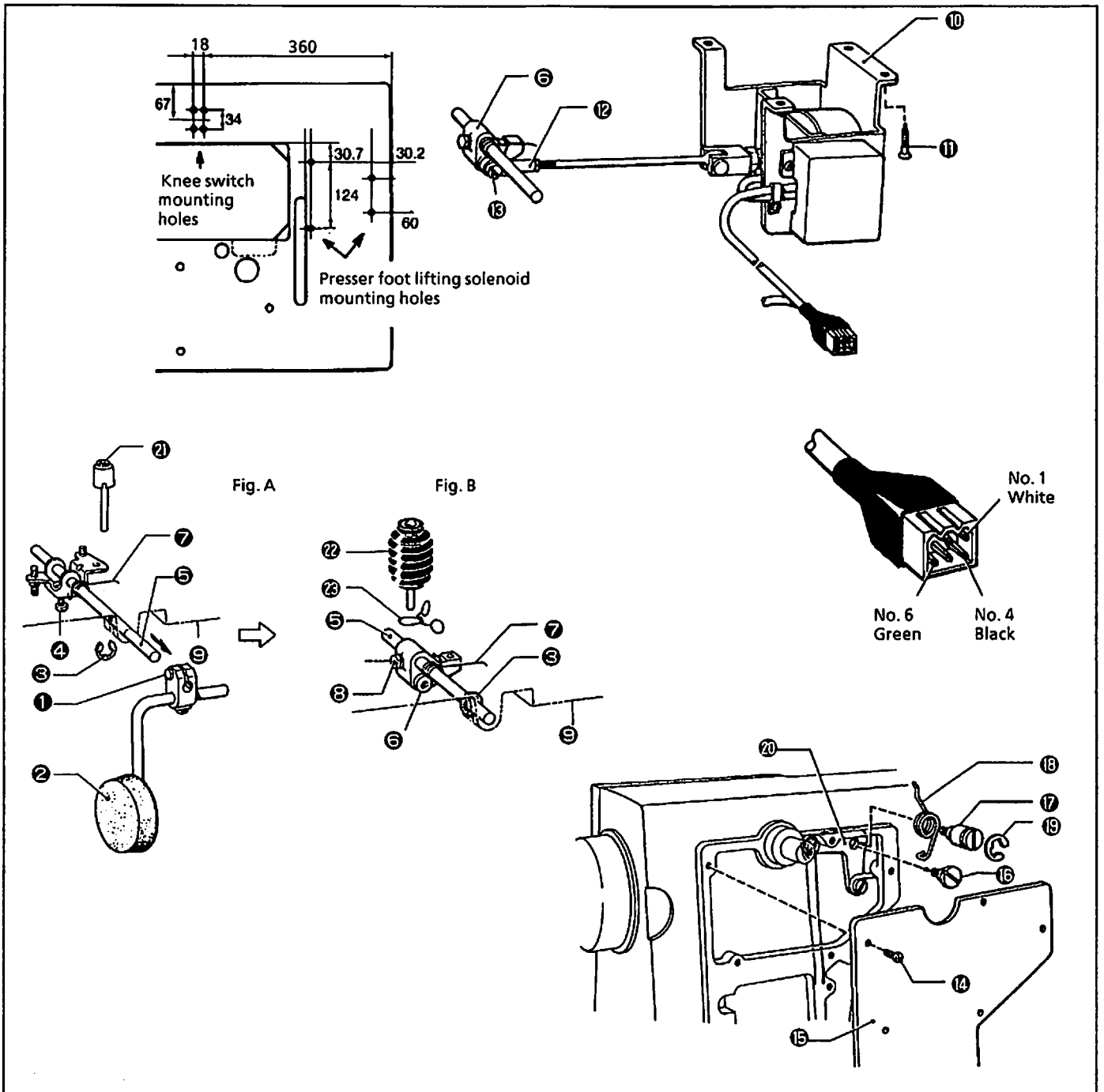

- 1) Loosen the bolt ①, remove the knee lifter assembly ② (Fig.A).
- 2) Remove the stop ring ③. Loosen the bolt ④, pull out the knee lifter shaft ⑤ (Fig.A).
- 3) Attach the presser foot lifting link ⑥ and the twist spring ⑦ to the knee lifter shaft ⑤. Attach them to the oil pan ⑧ with the bolt ⑧ and stop ring E ⑧ (Fig.B).
- 4) Attach the presser foot lifting solenoid assembly ⑩ to the position shown in the figure above, with the screw ⑪.
- 5) Attach the presser foot lifter regulating joint ⑫ to the presser foot lifting link ⑥ with the stud screw ⑬.
- 6) Connect the tips of the presser foot lifting cord with the pins 1,4 and 6 of the nylon connector 6.
- 7) Remove the six screws ⑭, remove the rear cover ⑮.
- 8) Remove the stud screw ⑯. In its place attach the screw ⑰, the knee lifter lever spring ⑱ and stop ring E ⑱.
- 9) Pinch the knee lifter lever spring ⑱ between the knee lifter lever ⑲ and the upper part of the arm.
- 10) Replace the knee lifter complying bar ⑲ with the knee lifter complying bar assembly ⑲.
- 11) Fasten the knee lifter complying bar assembly ⑲ with the clip ⑲.

Attaching the presser foot lifting solenoid set [subclass -006]

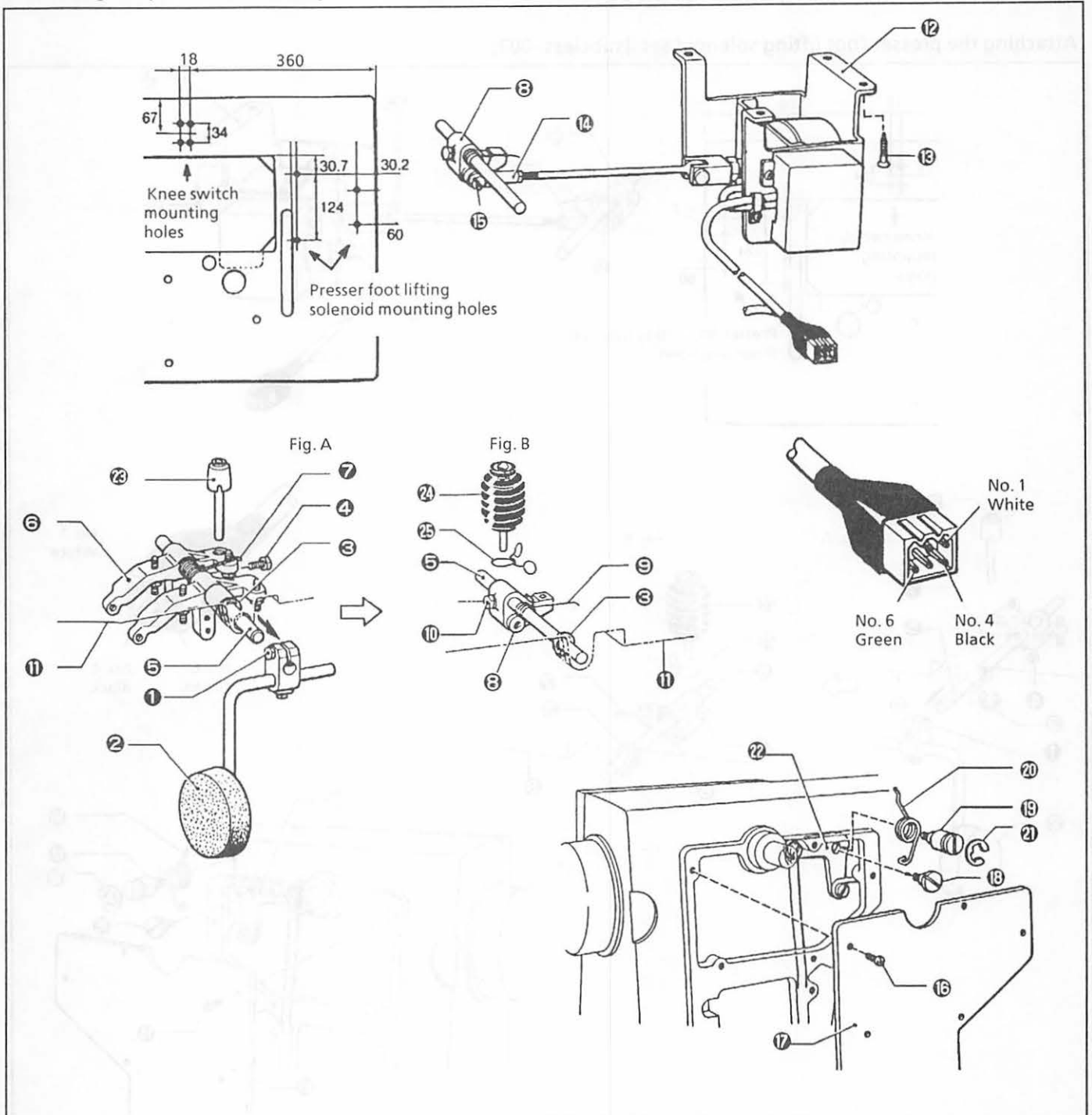

- 1) Loosen the bolt ①, remove the knee lifter assembly ② (Fig.A).
- 2) Remove the stop ring ③. Loosen the bolt ④ (Fig.A).
- 3) Pull out the knee lifter shaft ⑤ and remove the knee lifter ⑥ and the knee lifter twist spring ⑦ (Fig.A).
- 4) Attach the presser foot lifting link ⑧ and the twist spring ⑨ to the knee lifter shaft ⑤. Attach them to the oil pan ⑪ with the bolt ⑩ and the stop ring ③ (Fig.B).
- 5) Attach the presser foot lifting solenoid assembly ⑫ as shown in the figure above with the four screws ⑬.
- 6) Attach the presser foot lifter regulating joint ⑭ to the presser foot lifting link ⑧ with the stud screw ⑮.
- 7) Connect the tips of the presser foot lifting cord with the pins 1,4 and 6 of the nylon connector 6P.
- 8) Remove the six screws ⑯, remove the rear cover ⑰.
- 9) Remove the stud screw ⑮. In its place attach the screw ⑱, the knee lifter lever spring ⑳ and the stop ring ㉑.
- 10) Pinch the knee lifter lever spring ㉑ between the knee lifter lever ㉒ and the upper part of the arm.
- 11) Replace the knee lifter complying bar ㉓ with the knee lifter complying bar assembly ㉔.
- 12) Fasten the knee lifter complying bar assembly ㉔ with the clip ㉕.

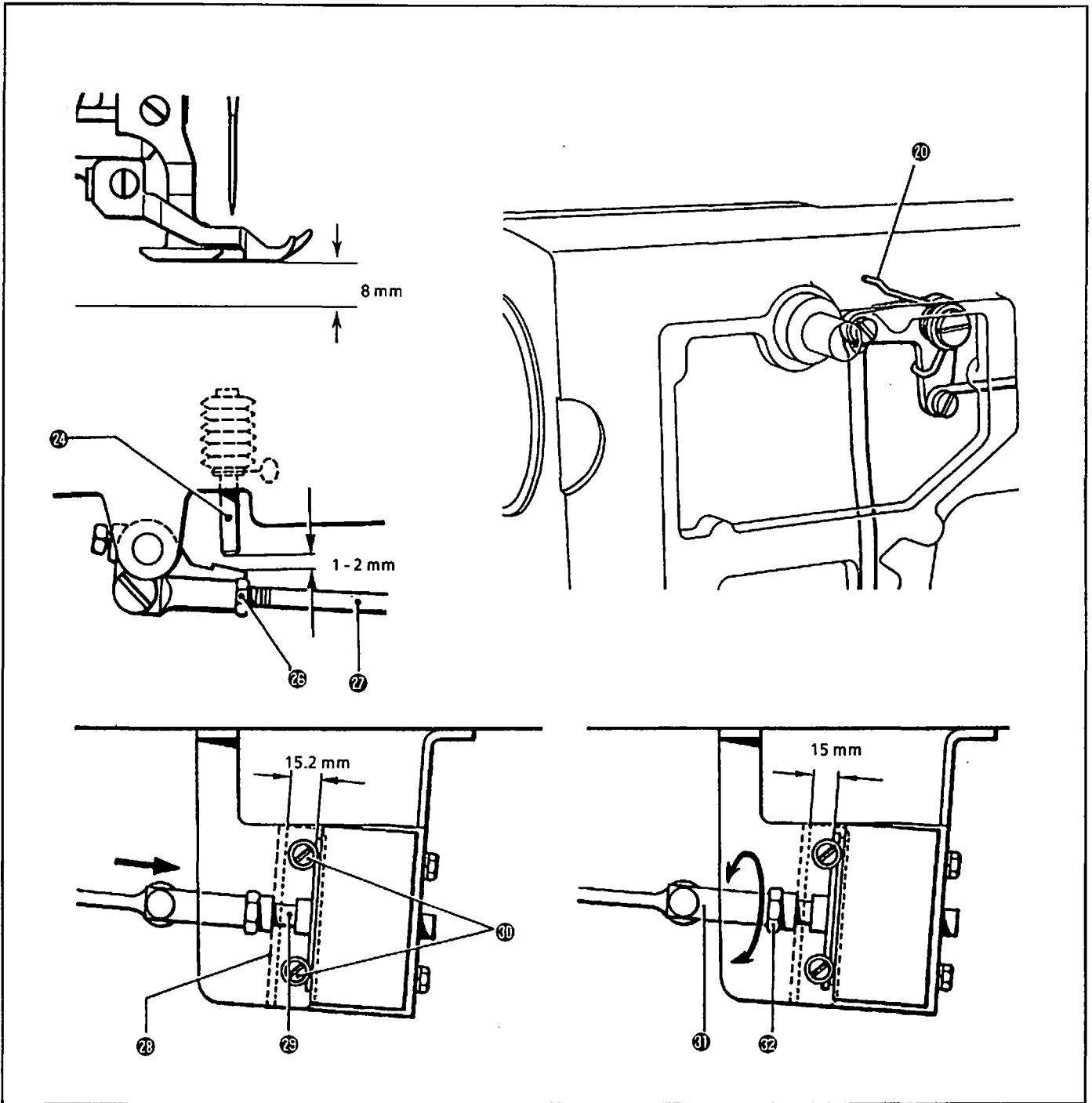

### Adjusting the presser foot height

Loosen the nut ②⑤. Adjust the presser foot lifter regulating rod ②⑦ so that the maximum rise of the presser foot is 8 mm when the presser foot lifting link ②③ is functioning.  
 (The play between the presser foot lifting link ②③ and the knee lifter complying bar ②④ should be 1 mm to 2 mm when the presser foot rise is adjusted to 8 mm).

### Adjusting solenoid

The solenoid is adjusted prior to shipping from the factory.  
 If the solenoid is replaced, adjust it as follows.

- 1) Push and hold the plunger ②⑨ in the direction of the arrow until it stops.
- 2) Attach the solenoid plate ②⑧ with the screws ②⑩ so that the gap between the solenoid plate ②⑧ and the front of the plunger ②⑨ is 15.2 mm.
- 3) Adjust the gap between the solenoid plate ②⑧ and the plunger ②⑨ to 15 mm by the link joint ②⑪. Tighten the nut ②⑫.

NOTE: Neglecting the knee lifter lever spring ②⑰ attachment will make noise during sewing.

## Attaching the knee lifter switch

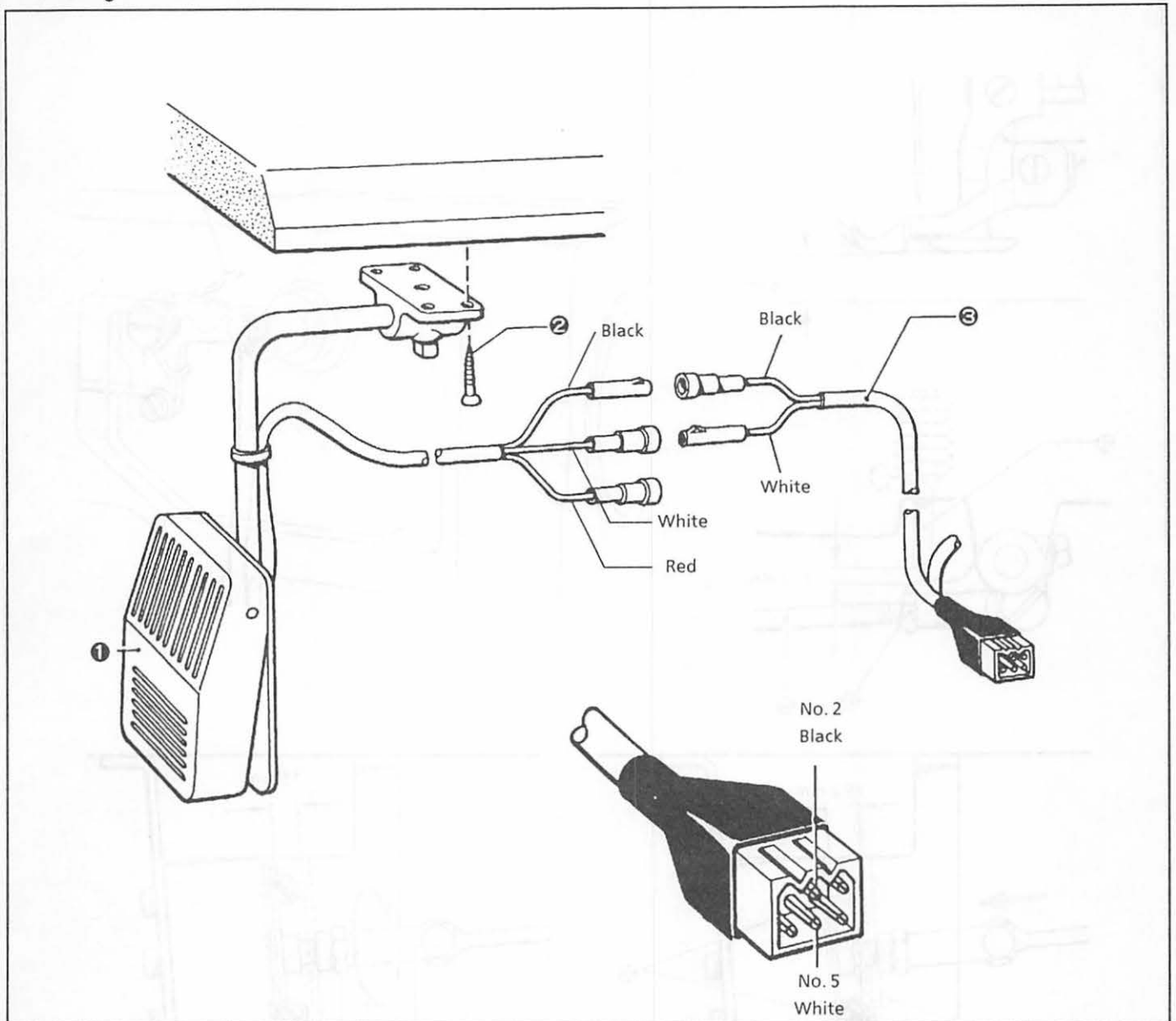

- 1) Attach the knee lifter switch ❶ to the table with the screw ❷. (Refer to the figure in page 55 or 56.)
- 2) Connect the tips of the knee lifter switch code ❸ with the terminal pins 2 (black) and 5 (white) of the nylon connector 6p.
- 3) Connect the plug with black cord of the knee lifter switch ❶ with the plug with the black cord of the knee lifter switch code ❸.
- 4) Connect the plug (white or red) of the knee lifter switch ❶ as described below;

In the case that the plug with white cord of the knee lifter switch ❶ is connected with the plug with the white cord of the knee lifter switch cord ❸;  
the presser foot is lowered when the treadle is not pressed, and the presser foot is raised when the knee lifter switch is pressed on.

In the case that the plug with red cord of the knee lifter switch ❶ is connected with the plug with the white cord of the knee lifter switch cord ❸;  
the presser foot stays up when the treadle is not pressed, and the presser foot is lowered when the knee lifter switch is pressed on.

# TROUBLESHOOTING GUIDE

## 1 Machine head

Problem	Cause	Check	Solution	Page
Needle breakage	Improper needle reattachment	Needle facing, height	Reattach needle.	/
	Bent needle. Blunt needle tip, jammed eye.	Needle	Replace needle.	/
	Improper feed timing		Adjust feed timing.	32
	Improper needle to rotary hook timing	Needle bar rise	Adjust needle to rotary hook timing.	31
		Needle bar height	Adjust needle to rotary hook timing.	31
		Needle to rotary hook gap	Adjust needle to rotary hook timing.	31
Thread wiper too high	Thread position wiper	Adjust thread wiper.	42	
Thread breakage	Improper threading	threading	Rethread.	/
	Bent needle. Blunt needle tip, jammed eye.	Needle	Replace needle.	/
	Improper needle installation	Needle facing, height	Reattach needle.	/
	Excessive needle thread tension	Needle thread tension	Adjust needle thread tension.	40
	Excessive bobbin thread tension	Bobbin thread tension	Adjust bobbin thread tension.	40
	Loose needle thread	Thread take-up spring operation	Adjust thread take-up spring.	40
	Insufficient rotary hook lubrication	Oil supply	Adjust oil supply.	/

Problem	Cause	Check	Solution	Page	
Thread frays, breaks	Burr in thread path		Remove with sandpaper.		
	Blunt needle tip		Replace needle.		
Skipped stitches	Improper needle installation	Needle facing, height	Reattach needle.		
	Wrong needle for application	Needle size, length	Replace needle with larger count needle.		
	Bent needle, blunt tip	Needle	Replace needle.		
	Blunt rotary hook point	Rotary hook point	Replace rotary hook.		
	Improper threading	Threading	Rethread.		
	Poor presser foot contact	Presser bar pressure		Tighten presser foot adjustment screw.	
		Presser bar height		Adjust presser bar height.	
	Improper needle to rotary hook timing	Needle bar rise		Adjust needle to rotary hook timing.	31
		Needle bar height		Adjust needle to rotary hook timing.	31
		Needle to rotary hook timing		Tighten presser foot adjustment screw.	31
	Needle thread remainder too short; does not remain in material.			Adjust pretension.	40
	Bobbin spins during thread trimming and bobbin thread remainder gets too short; won't rise.	Bobbin presser spring		Replace bobbin presser spring.	50
	Thread take-up spring tension too weak, won't raise bobbin thread.	Thread take-up spring tension		Adjust take-up spring tension.	40

Problem	Cause	Check	Solution	Page
Needle thread does not tighten.	Insufficient needle thread tension		Increase needle thread tension.	40
	Excessive needle thread tension		Decrease bobbin thread tension.	40
Bobbin thread does not tighten.	Excessive needle thread tension		Decrease needle thread tension.	40
	Insufficient needle thread tension		Increase bobbin thread tension.	40
Improper looping stitch tightening	Rough thread path	Thread path	Polish with fine sandpaper.	/
	Poor bobbin spinning	Tension of bobbin thread leader	Replace bobbin, rotary hook.	/
	Rotary hook to rotary hook stop gap too small	Gap	Adjust needle to rotary hook timing.	31
Improper thread trimming a. Needle, bobbin threads not trimmed	Movable knife, fixed knife do not overlap		Adjust knives.	38
	Worn, rough movable, fixed knife edges	Knives	Replace knives.	38
	Movable knife does not move	Thread trimming signal relayed?	Check electrical circuits; replace thread trimming solenoid.	/
b. Needle thread not trimmed	Improper needle attachment	Needle facing	Reattach needle.	/
	Last stitch skipped, needle thread not caught by thread cutter	Thread take-up spring stroke	Adjust thread take-up spring.	41
	Movable and fixed knives do not overlap		Adjust knives.	38
c. Bobbin thread not trimmed	Poor movable and fixed knives trimming	Knives	Replace knives.	38
	Movable and fixed knives do not overlap		Adjust knives.	38



Problem	Cause	Check	Solution	Page
Needle thread escapes at sewing start.	Tension disc does not open sufficiently.	Tension disc opening	Adjust tension release.	39
	Excessive pretension		Adjust pretension.	40
	Needle too heavy for thread		Needle size	/
	Up needle stop position too high, thread removed by thread take-up	Thread take-up height at up needle stop position	Delay up needle stop position.	41
Thread trimmer does not operate.	Thread trimming solenoid does not operate.	Check with tester	Replace thread trimming solenoid.	47
	Thread trimming signal not relayed		Check circuits. Refer to motor adjustment manual.	/
Thread wiper does not operate.	Needle thread remainder too long		Adjust pretension.	40
	Excessive material, presser foot resistance		Replace with presser foot have back channel.	/
	Timing too early; wiper thread before tension disc closes.		Adjust operating time.	/
	Thread wiper operation too short		Adjust operating time.	/

Problem	Cause	Check	Solution	Page
Thread wiper does not wipe thread.	Improper thread wiper facing		Adjust facing.	42
	Thread wiper strikes needle		Adjust thread wiper height.	42
	Thread wiper does not operate.		Set thread wiper solenoid switch to on, or replace solenoid.	
	Thread wiper operation is too short.		Adjust operating time.	
Reverse and forward stitch lengths do not match when using the quick reverse function.	Improper forward, reverse adjustment		Adjust eccentric pin.	33
Reverse solenoid makes noise.	Reverse solenoid gap too small		Adjust solenoid lever	44
No oil in gauge window; rotary hook not lubricated	Not enough oil pan	Oil	Add oil.	
	Filter clogged	Pump filter	Clean filter or replace.	
	Tube disconnected	Tube	Reconnect tube.	
	Tube broken		Replace tube.	
	Rotary hook lubrication adjustment screw tightened too far	Rotary hook lubrication	Loosen screw.	

**BROTHER INDUSTRIES, LTD.**

HEAD OFFICE: No. 35, 9-CHOME,  
HORITA-DORI, MIZUHO-KU, NAGOYA, JAPAN 467  
CABLE: BROTHER NAGOYA,  
TELEX: 4473696 BROS J